

# A HOUSE FOR ALL CHILDREN

*Planning A  
Supportive Home Environment  
for Children With Disabilities*

BY  
RICHARD V. OLSEN, PH.D.  
B. LYNN HUTCHINGS, M. ARCH.  
EZRA EHRENKRANTZ, F.A.I.A.

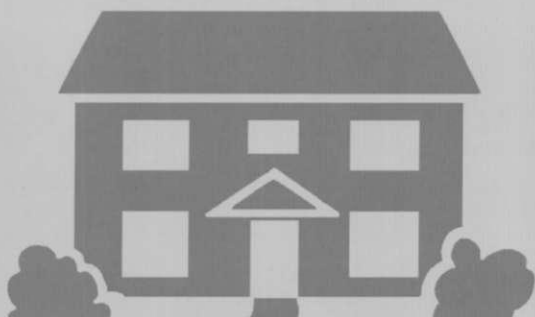

# **A HOUSE FOR ALL CHILDREN**

*Planning a  
Supportive Home Environment  
for Children With Disabilities*

BY  
RICHARD V. OLSEN, PH.D.  
B. LYNN HUTCHINGS, M. ARCH.  
EZRA EHRENKRANTZ, F.A.I.A.

Center for Architecture and Building Science Research  
New Jersey Institute of Technology  
University Heights  
Newark, New Jersey 07102-1982

Supported by the Robert Wood Johnson Foundation, Princeton, New Jersey

# Acknowledgments

*A House for All Children* could never have been written without the help and cooperation of many dedicated people. Assistance came from so many sources that we hope we are not overlooking anyone in this acknowledgment.

First, we want to thank our funder, The Robert Wood Johnson Foundation, and especially Ann Searight and Stuart Schear, for their financial assistance, their patience, and their emotional support over the past several years. Without their help—on many levels—this manual would never have happened.

Second, we want to thank the people who served on our review panel for their guidance and assistance along the way. This includes Melita Dolan, our barrier-free design expert; Jane Kovara, executive director of the Spina Bifida Association of New Jersey; and Lois Porter, the parent of a child with multiple disabilities.

We would also like to pay special tribute to the late Dr. Frank Dolan. Dr. Dolan, a rehabilitation engineer, served as technical adviser on the manual right up to his sudden and untimely death. His advice and feedback, along with those of his wife, Melita, have been invaluable. Dr. Dolan was a professional design consultant, a tireless advocate, and a true friend of people with disabilities. We are

extremely sorry he is not here to see the final version of *A House for All Children* to which he contributed so greatly.

Next, we must thank all of the people who helped us to recruit the families we interviewed for this study. In alphabetical order, the list includes people from the following agencies, schools, organizations, and advocacy groups—and if we overlooked anyone here, please accept our apologies and our thanks:

- Cerebral Palsy of Monmouth and Ocean Counties, Inc.
- Cerebral Palsy League of Union County
- Children's Specialized Hospital
- Disabilities Resource Center
- Dolan Consulting Group
- Educational Services Commission
- Lakeview School
- Matheny School and Hospital
- New Jersey Developmental Disabilities Council (DDC)
- Family Support Councils of the New Jersey DDC
- New Jersey Division of Developmental Disabilities
- Options
- SCARC, Inc.
- Spina Bifida Association, New Jersey
- Chapter Statewide Parent Advisory Network (SPAN)
- United Cerebral Palsy Associations of New Jersey, Inc.
- United Cerebral Palsy of Morris/Somerset, Inc.

And we would also like to thank the parents who both participated in our research and referred us to other families.

Finally, we must express our gratitude to the 68 parents and 12 children with disabilities who opened their homes and their hearts to us and who shared their insights so graciously and generously. From them we learned first hand about the challenges and rewards of parenting a child with a disability. Their experiences and expertise were the driving force behind *A House for All Children* and we truly appreciate their time and advice.

Again, thank you all.

The NJIT Press

Except as otherwise provided, the authors and publishers grant permission for materials in this publication to be copied for use by non-profit educational institutions for scholarly or instructional purposes only, provided that 1) the author and publication are identified, 2) proper notice of the copyright appears on each copy, and 3) copies are distributed at or below cost.

Copyright® 2000  
New Jersey Institute of Technology  
Newark, New Jersey 07102-1982

All Rights Reserved  
Printed in U.S.A.

# Preface

## A House For All Children

### Dear Families:

Our overriding goal in *A House For All Children* has been to provide guidelines for creating a safe and supportive home environment for children with physical disabilities. We feel strongly that a truly supportive environment is one that allows children with disabilities to function at the peak of their abilities—whatever the type and degree of their physical challenges. It also provides the range of physical, social, and emotional supports that can help parents and children deal with the demands of living with a disability

We began this book with three premises. Our first premise was that the physical environment of the home had a strong impact on the well-being of children with physical disabilities, their parents, and their siblings. Second, the physical, social, and emotional needs of the child and the family will change as the child grows and the home environment must also change to accommodate these evolving needs. Finally, the families of younger children with disabilities can benefit immensely from the advice, experiences, and insights of families with older children with disabilities.

The research we conducted—we interviewed 68 parents and 12 children—convinced us that each premise was correct. A properly designed home did make things easier for all family members. Needs did change over time as did the demands placed on the home. And

parents offered a wealth of insights about what worked and what did not, as well as much valuable advice on parenting a child with a disability.

Our extensive conversations with the families in this study revealed several key pieces of information to keep in mind as you read on. First, the demands of raising a child with a disability can be great—but so can the rewards for you and your other children.

Second, realize that you are not alone. Support and information are available from all kinds of sources—other families, service providers, state and county offices on disability, and advocacy organizations. See the Resource Guide on page 99 for how to contact them.

Third, both the law and the spirit of the times are on your side. You and your child have more rights now than ever before. The Americans with Disabilities Act and other pieces of legislation are slowly making the world more accessible. Opportunities for mainstream/inclusive education are expanding and so are athletic and recreational options for children with disabilities.

Fourth, more assistive technologies and equipment for people with disabilities arrive in the marketplace each day. These devices are designed specifically to help people with disabilities function more effectively and independently. They also make it significantly easier to care for children with disabilities.

Fifth, architects, builders, and planners have greater sensitivity to and familiarity with accessible design than in the past. This will make it easier for you to find competent professionals to make the modifications that may be necessary for your home.

Sixth, specialized equipment and home modifications can span a wide range of costs. We describe strategies for making your home safe and accessible in a variety of ways; each approach has a different price tag. Fortunately, financial assistance for home modifications is becoming available.

Creating a supportive home is an evolving process. Better designs and improved products are constantly being developed. We are always open to new information. If you have made a home modification or purchased a piece of assistive equipment that you think works particularly well, we would like to hear about it. Please drop us a note so we can pass the information on to other families.

*A House for All Children* is the culmination of three years of work. We have relied heavily on the experiences of families like yours who shared their time willingly and generously to make this book happen. We all hope that you will find it helpful.

Sincerely,



Richard V. Olsen, Ph.D.



Lynn Hutchings, M. Arch.



Ezra Ehrenkrantz, F.A.I.A.

The Center for Architecture and  
Building Science Research  
Room 335 Campbell Hall  
New Jersey Institute of Technology  
University Heights  
Newark, NJ 07102-1982

# Table of Contents

	Page
<b>Chapter 1: Why We Wrote This Book</b> .....	1
<b>Chapter 2: Changing Needs from Infancy to Adolescence</b> .....	7
<b>From Infancy to Toddlerhood</b> .....	7
<b>From Toddlerhood to the Pre-School Years</b> .....	8
<b>From Pre-School to School-Age</b> .....	9
<b>Moving into Adolescence</b> .....	11
<b>Chapter 3: Accessibility to the Home</b> .....	15
<b>Creating an Accessible Home</b> .....	15
<b>Accessibility Needs—They Are Everywhere</b> .....	16
<b>The Driveway</b> .....	17
Vans .....	17
Design Considerations for Conversion Vans .....	18
<i>“Tie-Downs” in Vans</i> .....	20
The School Bus .....	21
<i>Walkways/Access Through the Garage</i> .....	22
Getting to the Door .....	23
Ramps .....	23
On-Grade Entrances .....	27
Lifts .....	28
<b>The Front Door</b> .....	23
Getting to the Door .....	23
Ramps .....	23
On-Grade Entrances .....	27
Outdoor Lifts .....	28
<b>Getting Through the Door</b> .....	28
Unlocking the Door .....	28
Opening the Door .....	29
Getting Through the Width of the Door .....	30
Rolling Over the Doorsill .....	31
Closing the Door .....	32
<b>Other Problems</b> .....	32
<b>Chapter 4: Accessibility In and Around the Home</b> .....	33
<b>Doorways</b> .....	33
<b>Hallways</b> .....	35
<b>Controlling Access</b> .....	36
<b>Damage Control</b> .....	37
<b>Interior Stairs</b> .....	38
<b>Bathrooms</b> .....	39
Some General Things to Think About .....	39
Access and Basic Layout .....	39
<i>Diagonal Toilet Transfers</i> .....	42
<i>Lateral (Side-by-Side) Toilet Transfers</i> .....	43
Grab Bars .....	44
<i>Bathing Problems</i> .....	45
Bathtubs and Showers .....	45
Bath/Shower Seats .....	45
Bath/Shower Lifts .....	47
Hand-Held Showers .....	48

# Table of Contents

Other Considerations .....	48
Special Bathtubs and Showers .....	49
Shower Stalls .....	50
Roll-In Showers .....	50
<i>Problem Alert!</i> .....	52
Sinks .....	53
Other Considerations .....	54
Faucets .....	55
Toilets .....	56
Toilet/Potty Chairs .....	56
Helping the Child Get to the Toilet .....	56
Chairs That Roll Over the Toilet .....	57
Commode .....	57
Toilet Lifts .....	57
Bidet .....	57
Heat and Water Cleansing Apparatus .....	57
Changing Tables .....	58
<i>Toileting Trials/Ways to Help</i> .....	59
<b>Kitchens</b> .....	60
<i>Fostering Independence</i> .....	61
Basic Considerations .....	61
Cooking Devices .....	63
Other Kitchen Recommendations .....	64
<b>Laundry Rooms</b> .....	64
<b>Accessibility Around Your Property</b> .....	65
<b>Swimming Pools</b> .....	67
<b>Accessibility Guiding Principles</b> .....	68
<b>Chapter 5: The Ideal Home in the Right Neighborhood</b> .....	69
<b>The "Ideal" House Design</b> .....	70
House Form .....	70
House Layout .....	71
Movement Through the House .....	71
Specific Rooms .....	71
Bathroom .....	71
Kitchen .....	71
The Child's Bedroom .....	72
Windows .....	72
Considerations for Special Rooms .....	72
Getting In and Out .....	73
Garage .....	73
The Grounds .....	73
<i>Climate Control Systems and Electronic Equipment</i> .....	73
<b>What Makes a Good Neighborhood?</b> .....	74
Social Characteristics .....	74
Other Children .....	74
Adult Neighbors .....	75
<b>What the Location Offers</b> .....	75
<b>The Town's Physical Characteristics</b> .....	77
<b>Schools</b> .....	77
<b>Ways to Avoid Potential Problems</b> .....	77

<b>Chapter 6: Meeting Emotional and Social Needs</b> .....	79
<b>Ways to Develop Independence</b> .....	79
The Physical Environment .....	79
Special Equipment and Technologies .....	80
Activities .....	80
Going Places, Doing Things .....	80
Taking Advantage of Social Opportunities .....	80
Treatment/Care .....	80
Disability Education .....	80
Attitudes Toward the Child .....	81
<b>Meeting Social Needs</b> .....	81
Potential Obstacles .....	81
The Environment .....	81
The Child .....	81
Negative Attitudes of Other People .....	81
Other Stumbling Blocks .....	82
<b>Coping Strategies</b> .....	82
The Environment .....	82
Personal Strategies .....	82
Participation in Formal Activities .....	83
Experiences That Lead to Socializing .....	83
<b>Providing Privacy</b> .....	83
Toileting .....	83
Inside the House .....	83
Outside the House .....	83
Bathing .....	84
Social Privacy .....	84
<b>Chapter 7: Parent to Parent: Advice from the “Experts”</b> .....	85
<b>The Home Environment</b> .....	85
<b>Location</b> .....	86
<b>Getting Treatment, Care, and Help for Your Child</b> .....	86
<b>How You Relate to or Treat Your Child</b> .....	87
<b>Obtaining Information</b> .....	87
<b>Equipment and Assistive Technologies</b> .....	88
<b>Advice About Schools</b> .....	88
<b>Why Listening to Other Parents Is Important</b> .....	89
<b>Chapter 8: The Children's Story</b> .....	91
<b>Memories of Childhood and Changing Needs</b> .....	92
<b>Social Life</b> .....	93
<b>The Children's Ideal Home</b> .....	93
<b>The Children's Ideal Neighborhood</b> .....	94
<b>Reactions to the School Environment</b> .....	94
<b>Comparing the Two Perspectives</b> .....	95
<b>The Children's Advice</b> .....	95
<b>Closing Comments</b> .....	96
<b>Developmental Checklist</b> .....	97
<b>Resource Guide</b> .....	99

# Chapter 1

## Why We Wrote This Book



We all want the best for our children: the best opportunities, the best health, the best medical care when needed, the best friends, the best schools, and the best possible home. In their homes, children need safety, security, independence — and the reassurance that they can live at the peak of their abilities. For children with disabilities, these needs are particularly pronounced. Physical challenges can make it difficult to do things that other children take for granted: getting in the front door, moving from room to room, climbing stairs, playing in the backyard, bathing, toileting, dressing, getting a snack — even just being with friends. Consequently, the need for an accessible and supportive environment is especially strong in homes where there is a child with a physical disability.

However, the reality of providing care can occupy the lion's share of parents' overtaxed attention and energies. And while the home environment has a tremendous effect, both positive and negative, on families who are raising a child with a disability, parents are often unprepared for this impact. Before they realize it, their child is bigger and harder to care for, and they now have major problems because their homes are not accessible.

**With this reality in mind, we set the goals for this parents' manual. They are:**

- **To stress the importance of a barrier-free and supportive home.**
- **To remind you that needs will change over time as your child grows. Your home should adapt and "grow along with your child."**
- **To provide practical advice for creating the proper level of physical, social, and emotional support in your home.**
- **To encourage you to think about and plan for the future. When the need to modify the home with ramps, roll-in showers, and other assistive devices appears, it will not come as a shock.**

Here are some things to keep in mind as you read this book.

***1. Parents and their children with disabilities are a team.*** You cannot create an environment for one member of the team without considering the needs of the other.

A home that is safe and accessible will allow children who have the ability to bathe, dress, toilet, and eat—what professionals call "activities of daily living" (ADLs)—as independently as possible, without fear of falling, straining, or



burning themselves. Environments that support independence also foster feelings of autonomy and self-esteem. As children who feel good about themselves are generally easier to raise, this can make parenting less taxing. Having a home that is safe also reduces your anxiety that your children will hurt themselves. Accessible environments can also make it possible for you to teach these all-important ADL tasks to your children without constantly battling physical barriers in your home. If your children are more dependent, a truly accessible environment makes it easier for you to bathe, toilet, and dress them. *This decreases the physical strain of caregiving.*

**2. Needs will change over time.** Caring for an infant and a toddler is quite different from raising a school-age child and dealing with an adolescent. As children mature and grow bigger, their needs change with them. They can be harder to care for both physically and emotionally. While focusing on the demands of the moment, parents need also to look to the future. Ask yourself: Is this the best neighborhood for us down the road? Will this house work for us when our child gets bigger and requires greater accessibility? Planning for the future is essential. If you must move, it is better to do it when your children are younger. This will give them the opportunity to form longer-lasting friendships with other children in their neighborhoods and schools. Moving during adolescence can be quite traumatic and isolating for all children. It is especially so for children with disabilities.

**3. Issues interact with each other.** As you read through this manual you will notice that we discuss accessibility, independence, social contacts, and the ideal home and neighborhood in separate sections. These issues do not exist in isolation, however. A house that is accessible will encourage your child's independence and social life. These will naturally lead to a heightened sense of well-being. Living in an ideal house in an ideal neighborhood will enhance independence and social opportunities for many of the same reasons. You will see a lot of ideas and issues that overlap as you read on in this book. It was impossible to discuss one without touching on the others.

**4. Every situation is both similar and different.** The needs for safety, accessibility, independence, and meaningful social opportunities exist in every household. However, the degree to which they can be achieved varies widely from home to home. The type and severity of the child's disability and health status, the structure of the family unit and its finances, the physical features of the home, and the quality of the neighborhood all influence what can be accomplished in the home to meet these needs.

The tremendous variation in disabilities and households determined our overall focus. Given the differences in situations, we could not possibly redesign everyone's home. Consequently, we are presenting ideas for creating an accessible and socially and emotionally supportive home rather than "working drawings" for how to do so. This is a book of ideas and concepts, not tape-measure specifics. Our aim is to raise your awareness of the need to modify your home and to present some

broad guidelines for doing so. When it becomes time to put the advice in this book into practice, we strongly urge you to consult professionals—physical and occupational therapists, rehabilitation engineers, architects, and builders who specialize in accessible housing.

### Where the Information Came From

We gathered information for this book from two critical sources: our own research experiences with people with disabilities, and consumer information from the "true experts"—parents who have been raising a child with a physical disability and who customized their homes to do so. We felt strongly that these consumers—both parents and children—had a wealth of insights that would benefit other families. This assumption had proven true in all our prior work with people with disabilities and it was the case in the present study as well.

The consumer information came from detailed interviews with over 65 parents and 12 of their children with disabilities. We were interested in what tactics families used to create supportive environments in their homes and how effective the strategies were. We wanted to talk with people who were sensitive to environmental issues to the point where they made physical changes in their homes that they could then evaluate for us. As a result, we only interviewed families who had modified their residences or built special homes to accommodate their children's disabilities.

The interview covered a wide range of topics that we felt were relevant to raising a child with a disability at home. Among them:

- Exploring how needs change over time. We asked parents (and children) to describe their experiences and problems at each of the four major developmental stages: infancy and toddlerhood; pre-school; school-age; and adolescence/early adulthood.
- Evaluating environmental strategies: what worked and what did not. We asked parents to evaluate every alteration they made in their homes (or included in the construction of their new homes) because of their child's disability and every piece of assistive technology they purchased. We also asked them to rate how important it was to make these changes and whether or not the alteration could have been modified to make it work better.
- Determining how the physical environment of their home affected their child with a disability. We asked each family to rate their present home according to its impact on their child: positive, negative, or no impact, and to explain why this was so.
- Identifying critical design features for new housing. We asked parents and children to describe what an ideal home and neighborhood would be like for them if they had to move.
- Exploring social and emotional needs. We asked parents to describe their tactics for meeting their child's non-physical needs for independence, privacy, and socialization.

We see this book as a source of support and advice for parents of younger children, so we asked these more experienced parents two additional questions:

- Would they do anything differently if they had to live these years over again?
- What advice would they give to parents who have just found out that their child has a similar disability?

As we recruited only families who made changes in their homes we cannot claim that our families are representative of all families with children with disabilities. They are, however, fairly representative of families who modified their homes or built customized ones. Our primary goal was to identify design features that worked. The uniqueness of our study group allowed us to do this.

### The Families

We spoke with 65 families who had 67 children with disabilities. (Two families had two children with disabilities.) All of the children in our study had a physical disability. However, the type and degree of disability varied, with some children also having intellectual limitations. Some disabilities were more prevalent than others, as they are in the real world. For example:

- 53 percent of the children in the study had cerebral palsy.
- 15 percent had spina bifida.
- 7 percent had muscular dystrophy.
- 25 percent had disabilities from a variety of other conditions, such as Rett Syndrome, hydrocephalus, Pallister-Killian Syndrome, meningitis, microcephaly, brain tumor, head trauma, and so on.

The common thread was that all of the children had a physical limitation that made it difficult for them to perform their activities of daily living. For example:

- The vast majority of the children (79 percent) used a wheelchair regularly.
- Approximately 10 percent used wheelchairs or other mobility devices part of the time.
- Another 10 percent used braces, crutches, or walkers, often in addition to a wheelchair.

Since wheelchair use was so prevalent, a large portion of this book deals with wheelchair accessibility in the home.

In addition to mobility problems:

- 66 percent of the children had physical limitations above the waist.
- 55 percent of the children also had some form of intellectual limitation.
- 10 percent had sensory disabilities (hearing or vision) in addition to a physical limitation.
- 64 percent also had a communication impairment.

As these descriptions indicate, many of the children in the households we visited had multiple disabilities.

The 67 children also varied in age. Since we wanted parents to discuss how their child's needs changed over time, we concentrated on interviewing families with older children. For example:

- 2 percent of the children were pre-school age (ages 2 to 4).
- 37 percent were school-age (ages 5 to 11).
- 55 percent were adolescents (ages 12 to 19).
- 6 percent were young adults (age 20 and older).

Two-thirds of the children (65 percent) were boys and 35 percent were girls. In contrast, the majority of interviews (75 percent) were with mothers. Only 6 percent were with fathers and 19 percent were with both parents together. The majority of parents (75 percent) were married while 18 percent were divorced and 6 percent were widowed.

We tried to interview families who lived in house styles that are typically American. For example:

- 48 percent of the families lived in houses with two or more stories. These included Cape Cods, Colonials, Tudors, and contemporaries.
- 38 percent owned ranch style or other one-story homes.
- 11 percent had split-levels.
- 3 percent were apartment dwellers.

Renters are not usually able to modify their units to the extent that people who own their own homes can, and only two families in our interview group (3 percent) lived in apartments. The families in our study resided in suburban, small-town, beach, rural, and semirural communities.

Although we did not specifically ask parents about their financial situation, judging by their homes the families in our study had a range of incomes. Obviously, it is easier to create an accessible home when you have "deep pockets," so we deliberately tried to mix the income levels of the families we interviewed. We wanted to offer suggestions for equipment and

*“All of our home modifications aided in independence and caregiving.”*

*“This house is not good. It’s not practical. Things are too far away. It’s a hard-work life—you don’t need a hard-work house.”*

modifications that varied in scale and costs. For example, a child can shower in a prefabricated, pop-in, accessible shower stall or in a custom-made, oversize, roll-in, hand-tiled shower with expensive fixtures. Whenever possible, we make recommendations that can be implemented in a variety of price ranges.

### Why the Physical Environment of the Home Is Important

A major assumption for this study was that the family house or apartment is not a neutral backdrop and that it plays a key role in the lives of children with disabilities and their parents. To test this assumption, we asked the parents to rate the impact of the *physical environment* of their homes. When we looked at their responses, we found that:

- 94 percent of the parents felt that the physical design of their home affected their children in some meaningful way.
- The impact of the home environment applied to nearly all families. This was regardless of the severity of their child's disability and the type of housing they had.
- Two-thirds of the parents felt that their homes had a positive impact on their children and one-fourth reported a negative effect. Only 6 percent—four parents—felt that their home environments had no particular effect.

These responses led to two critical questions: *how* the design of the home actually assists the child and *what* are the features of the home that help or hinder the child.

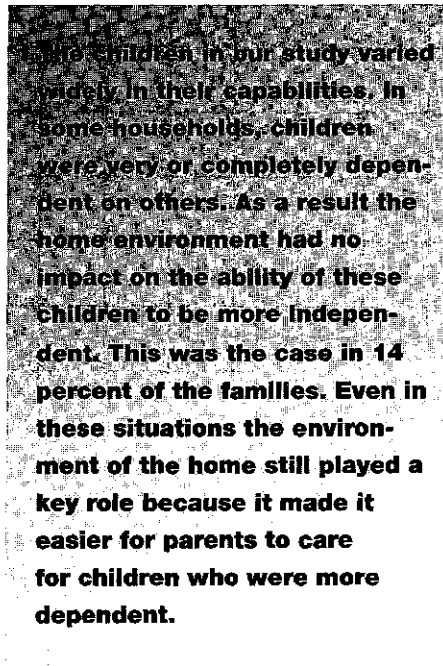

*“Modifications made my child feel safe, so he was less hyper.”*

### Successful Home Environments

A home setting that helped both parents and children was one that:

- **Improved safety:** the children felt safe in their homes.
- **Increased independence:** the children could do more on their own.
- **Stimulated mobility:** the children were able to move around the house, to come and go as they pleased.
- **Offered privacy:** the children had their own space.
- **Encouraged interaction:** the children had contact with other people.
- **Provided access to recreation and stimulation:** the children could play, watch television, listen to music, and entertain themselves.

*“The design of the house made my child more able to wheel around and get to places on her own. It accelerated her development.”*

- **Assisted caregiving:** the house made it easier for the parents to provide, or assist with, their children's care.

We were particularly interested in knowing how the environment helped children to function more independently and to socialize. When parents talked about independence, they told us that:

- An accessible, one-level house made it possible for older children to come and go or move around the house as they pleased.
- A properly designed home helped children to be more independent and to do their own "activities of daily living," such as showering, toileting, and dressing.
- Specific equipment increased independence: a shower massage helped a young girl to wash herself, remote controls allowed children to turn on the television, a stair lift provided access to a recreation room, and special low beds and lifts helped children get in and out of beds and chairs with minimal assistance.

*“My child’s bedroom became the focal point for activities. A good TV, cable, and VCR make his bedroom a social draw. He can easily be where things are happening.”*

When they described how the physical features of their homes encouraged socializing among the family and friends, parents mentioned that:

- One-level ranches made it easy for children to move around the house. They could go anywhere and be with other family members wherever they were.
- They set up children’s bedrooms as activity centers. Equipping them with televisions, VCRs, CD players, computers, and video games made it possible for the children to play with friends and siblings in their bedrooms.
- Having accessible family rooms and swimming pools made it easier for children to be with other people.

Most of the design characteristics that supported safety, independence, and socializing related to accessibility. These included design features such as:

- a one-level house
- large rooms
- wide doorways, no thresholds
- ramps and lifts that made it easy to get into the house
- accessible bathrooms and kitchens
- ample storage space

Other helpful house features included:

- flat terrain in the neighborhood
- a good, friendly community
- a swimming pool and a nice yard

All of these features are discussed in greater detail in following chapters.

## Chapter 2

# Changing Needs from Infancy to Adolescence

A major focus of this work with families was to identify how needs change over time as children with disabilities grow up. Like all children, your little child will experience many changes on the path to adolescence and young adulthood. Naturally, the quality and quantity of care and assistance that you provide along these various developmental stages will also change. So will the type and level of support that you will need from your home environment.

One of our assumptions in this study was that the demands of caring for an infant/toddler, a pre-schooler, a school-age child, and an adolescent would be very different from each other. To see if this assumption was true, we asked the parents of older children in the group to describe their experiences during each of these developmental stages.

The discussion of each stage began with a general question about what those particular years were like. We asked parents to describe the problems that emerged and whether the situation became easier, harder, or both easier *and* harder as their children moved from one stage to another. We felt that there was a lot of practical advice that more experienced parents could offer to newer parents, to alert them to the many ways that needs can change over time and to what may lie ahead. We hope that this information will help you to prepare yourself psychologically and to prepare your home physically for these changing needs in the best way possible.

### **From Infancy to Toddlerhood (Birth to Age 2)**

*“Things were easy. He was light—like a normal infant.”*

*“The early years were learning years for all of us.”*

*“At this point we made no changes in our home, but major changes in our life-style.”*

Parents reported a wide range of experiences during the infant/toddler years. In some situations, the signs of the disability were minimal at this stage or they appeared later in childhood. In these situations, parenting was similar to caring for any infant or toddler. The baby was small and easy to lift and carry. He was in diapers. The parents bathed him in the kitchen sink or in an infant tub. He ate in a high chair, crawled on the floor if he could, and generally "got into everything."

Other families went through a very difficult infant/toddler period. The baby was not diagnosed but the parents knew *something* was wrong. There was constant anxiety but no definitive diagnosis or information. To make matters worse, some parents received no physical or emotional support during this time of uncertainty.

In still other families, the parents knew immediately that there was a major problem with their child. There were severe physical and medical problems: seizures, feeding disorders, constant crying, reflux, sleep apnea, communication problems, and so on. Some families spent a good part of their child's early years in the hospital while the child underwent testing and corrective surgeries. In some households, the constant care, emotional strain, and financial worries led to serious family problems.

When it came to treatment, some families got involved immediately with early intervention programs. These programs offered physical therapy, speech therapy, day programs, and daycare. Other parents recalled needing early intervention but not receiving it. Still others, whose child's disability had either not yet emerged or not been diagnosed, had no idea that treatment was even necessary.

Few parents modified their homes during the infant/toddler period. Families focused mainly on equipment needs, such as:

- mobility devices: strollers, standers, and specialized bicycles or tricycles
- seating/positioning/feeding equipment
- monitoring instruments: intercoms, baby monitors, or apnea (breathing) monitors
- bathing aids: infant tubs, special bath chairs and cushions

For parents who have a child with a disability, the infant/toddler years can be intense. Parents have many questions and concerns. A mass of information must be obtained and then digested. Tremendous amounts of emotion and physical care are often expended during this time. Many parents reported feeling completely

overwhelmed. Because of these stresses and strains, few families thought about the physical environment of their homes. They had too many other things to worry about. This is completely understandable.

However, these early years are exactly the time when you *should* start thinking about your home. In the same way that there are early intervention programs for therapy and respite care, you may also need some "early environmental intervention" as well. There may be some small-scale changes that could make your life easier. This is also the time to consider much larger questions: Is this the best house, the best neighborhood, the best community and educational system for a child with a disability? Looking realistically at these issues may help you plan for the future, especially if moving is an option. A number of parents wished that they had moved, or had moved sooner than they actually did.

#### From Toddlerhood to the Pre-School Years (Ages 2 to 5)

Parents described the transition from the infant/toddler years to the pre-school stage in numerous ways. At this point, some children's needs became greater. In addition to physical and medical concerns there were now social and psychological issues to consider. When we asked parents if things got easier or harder as their child moved into the pre-school stage, the responses varied:

- 29 percent of the parents said this stage was harder.
- 20 percent said it was easier.
- 10 percent said it was both easier and harder or "just different."
- 8 percent thought the two stages were the same.

*"He was bigger and not as portable. We needed to adapt more things and we needed more equipment."*

Families who thought the pre-school years were harder described the following difficulties:

- Their child was bigger and more difficult to carry or transport.
- Bowel and bladder problems came into play.
- More (and more expensive) equipment was needed.
- Medical problems continued or became worse.
- Their child's abilities or condition deteriorated.
- Problems developed in the immediate and extended families.
- There were emotional issues to deal with, such as nightmares and social withdrawal.

*"It was much easier. He did more for himself and was becoming more verbal."*

While care generally became more difficult as the child grew, this was not always the case. One-fifth of the parents felt that life became easier during this stage because:

- Their child was in school or in a full-day program. This provided respite and more freedom for parents.\*

*\* If you are the parent of a toddler, keep this in mind when you are having a difficult time. Things should improve when your child goes to school or a day program. You will have more time for yourself and your other children.*

- They became better educated about their child's disability and more knowledgeable about ways to deal with it.
- Their child's condition improved. Earlier medical problems were resolved. The child became verbal and/or could do more for herself. In certain situations, the child was able to participate more fully in family activities.
- Family life improved after everyone had had more time to adjust to the situation.

The small percentage of parents who thought that things became both easier and harder or just different during the pre-school years mentioned one or more of these same reasons.

When we looked at the home environment, some new issues developed during these years. Playing and socializing with other children often required custom-designed equipment and spaces. In some cases, toilet training was taking place and mobility needs were emerging or increasing. Yet many of the changes that parents made in their homes at this time still only involved equipment. Parents bought standers, and strollers, and bicycles. They purchased special seating and bath chairs. Potty chairs and grab bars appeared in bathrooms. Higher beds and beds with railings went into bedrooms. Several parents bought vans during this time along with special car and travel seats.

At this stage, some families did purchase wheelchairs, and accessibility concerns surfaced immediately afterward. More room was needed to accommodate the wheelchair. Ramps had to be built so the wheelchair could get in and out of the house. And larger vehicles were bought to transport the child in the chair. The impact of the environment was starting to be felt

in many homes during the pre-school period.

#### From Pre-School To School-Age (Ages 5 to 12)

As the child moved on to the school-age years, family life shifted in a number of ways. This was not surprising. Household schedules and routines tend to readjust in all families when children start school on a full-time basis. The child is out of the house more, there are new friends, parents focus attention on the quality of the school, and so on.

For many of our families, it became significantly harder to provide care at this point in their child's development. When parents described the school years:

- 57 percent felt that life became harder.
- 11 percent thought it was easier.
- 21 percent said some things were easier, other things were harder.
- 8 percent felt that things were either the same or different rather than easier or harder.

*“It was physically harder—wheelchair transfers; getting in and out of the van; and carrying him upstairs. Emotionally it was harder for my son. He was now aware of his own limitations. . . tough territory now, he wants to do what everyone else does.”*

Families who felt life was more difficult during this time reported that:

- Their child had additional or ongoing medical problems or his physical condition deteriorated. These parents described falls, seizures, surgeries, broken bones, and other medical issues.
- Behavioral or emotional difficulties emerged. Some children had problems with aggression, isolation, boredom, and the realization of their limitations. Some parents also mentioned that their children were now developing distinct personalities with stronger preferences and opinions that had to be acknowledged.
- School-related issues surfaced. The inadequacies of local school systems became apparent. There were problems with inaccessible schools and unsupportive school systems. Difficulties with local boards, administrations, and school transportation systems emerged.
- Problems in the family continued or began. These stresses ranged from dealing with overprotective grandparents, and lack of help from other family members, to sibling jealousies, and balancing the demands of a child with a disability with the needs of other children.
- There were problems with approvals and reimbursements from insurance companies.
- Most significantly, the child continued to grow. He was bigger now and more awkward to lift and carry. Increased size and weight made it harder to move and transport the child, or to transfer him from the wheelchair to the bathtub, the toilet, or the car. It was more physically



taxing to dress him. One in three families mentioned that care was more demanding because of the increased size of their child during these years.

- The physical environment of the home created more problems. The impact of a poorly designed home became evident during this time. Parents talked about inaccessible bathrooms, narrow halls, problems with stairs, and the need for a bigger kitchen to accommodate a power wheelchair. At this point, many parents realized that their house was just too inaccessible to work for them. This sentiment was shared by parents of children from all disability groups.

*“We had a choice—make modifications or move.”*

When we looked at the changes parents made in their homes during the school years, we saw many more accessibility-related modifications. More children were using manual or power wheelchairs. As a result, more families built ramps to their doors and decks. They also widened doorways and halls so their children could maneuver better in a wheelchair. Some parents installed lifts because the child was now too heavy to carry upstairs—or they created a bedroom for him on the first floor.

A number of parents now purchased hospital beds, intercoms, and other equipment so they could communicate with or monitor their children. Bedrooms were sometimes enlarged to accommodate wheelchairs, and closets redesigned to make them more accessible.

Parents also renovated or added new bathrooms to provide accessible tubs, showers, sinks, and toilets. Their child was just too big or too heavy to bathe or toilet in an inaccessible bathroom. In addition, children with more abilities now wanted privacy for performing these ADLs independently. The only way to accomplish this was in a totally accessible bathroom. During the school-age years, some families also started to modify their kitchens. They needed more room for the wheelchair. They also wanted more accessibility so that a more independent child could get his own snacks and prepare meals.

Many families also bought vans with portable ramps or automatic lifts during

these years. Several families installed swimming pools, which their children could use for therapy and for socializing with other children. Finally, school needs had to be accommodated. Parents bought special computers and created accessible desks and homework stations.

Because of the growing size of the child and the shift in his social and emotional needs, the school-age years required a major mobilization of the physical resources in the home. As the chart below shows, parents made more changes during this period than in any of the other developmental stages. Even so, in looking back, many parents wished that they had moved or modified their homes even earlier than they did.

Number of Modifications by Age Group

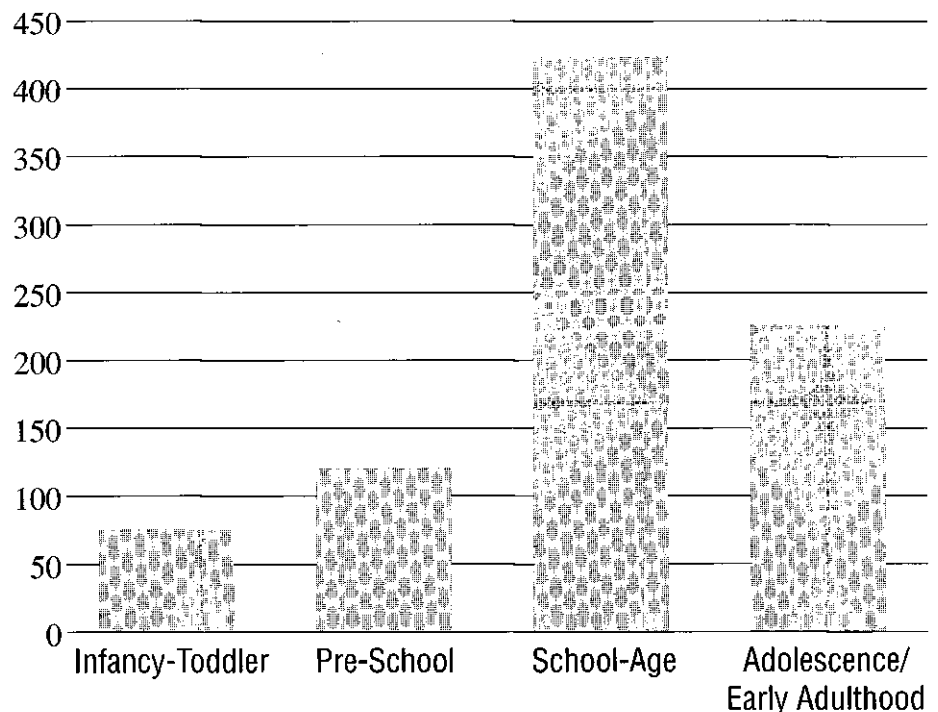

So, while the school-age years may be the time that physical changes in the home are most needed, you may want to consider making them even earlier. This will help to prepare you and your child for the demands of these hectic years. Again, we want to stress the importance of thinking ahead. If your house is not going to work for your family in the long run, it is better to move sooner rather than later. You do not want to uproot your family at this critical time—when your children are in school and they have already established friendships.

While the school-age years were harder for many parents, not all families found them so. In several households (13 percent of our families), the school-age years brought fewer stresses and strains. When they explained why, parents gave similar reasons to those they gave for the pre-school years:

- The child developed more skills and became more self-sufficient. He became more verbal and developed more independence with toileting, using a wheelchair, and getting out of bed.
- The child's physical condition improved. There were fewer illnesses or seizures, and he was more stable medically.
- There were behavioral improvements and emotional developments. The child was crying less, enjoying the world more, and was friendly and well-adjusted.
- Parents had more time to themselves. The child was spending more time in school or there was more respite care.

We would like to point out that there were joys and rewards at each stage. Despite challenges, things were not all bad.

*“It was easier in some ways—not dealing with the same emotional issues. We learned to deal better with doctors and educators; became more accepting of the situation; managed to find more services; and got more respite care.”*

#### Moving into Adolescence (Ages 12 and Up)

Adolescence is a difficult time in any household. Conflicting desires to be independent yet wanting to be taken care of, combined with hormonal surges, peer group pressures, fear of rejection, sexuality issues, and concerns over school and career plans create considerable emotional volatility in the home. Families with a child with a disability are not spared this turbulence. In fact, of the 32 parents of adolescents in our study:

- 60 percent felt these years were harder than the school-age years.
- 16 percent thought these years were easier.
- 19 percent described life as easier in some respects and harder in others.

No one thought adolescence was the same or just different from the school-age years and there was no particular relationship between these responses and the types of disabilities that the children had.

Things became harder during the teen years for many of the same reasons that made the school-age years more difficult than the pre-school ones:

- The child was still growing and getting steadily bigger, heavier, and harder to care for. Carrying and lifting were more difficult, wheelchairs and other mobility aids were larger and harder to maneuver and transport. Accessible transportation was more of an issue and difficulties with stairs and toileting became worse.
- Behavioral and emotional issues became more of a concern. (This is totally understandable given the emotional strains of adolescence.)
- Social problems continued or became worse. The child was isolated. Other teens were mean or resistant to friendships. Maintaining a social life generally became harder.
- Physical and/or medical deterioration occurred. The child had seizures, developed scoliosis, required more surgeries, and so on.
- School problems continued. Schools were inaccessible, mainstreaming created difficulties, and negative attitudes of school officials remained a problem.

*“It’s getting harder—he’s bigger, moodier, and we are spending money on lawyer’s fees to keep him in a less restrictive environment in an out-of-district school.”*

Parents reported that their teenager was moody, difficult to deal with, more aggressive, and frustrated by her limitations and the barriers they presented.

*“Things got easier. We moved to a house that was more accessible.”*

While life became harder for many families during adolescence, again this was not true across the board. Some parents reported that the adolescent years brought improvement; others felt that some things became harder, while others became

easier. In some families, life with an adolescent became less difficult because:

- The teen continued to develop more skills and independence. Communication was improving, self-transferring occurred, the adolescent could entertain herself, and school taught her to be more independent.
- There were supports from the physical environment of the home. Parents who had moved to a one-level house or built an addition to the first floor or installed a lift felt that these environmental changes made life easier.

*“It was easier. He was crying less, more independent. He can shave and entertain himself.”*

A small number of parents also reported that an improved family situation, better emotional behavior, fewer medical complications, and more understanding of the situation made life less pressured during adolescence.

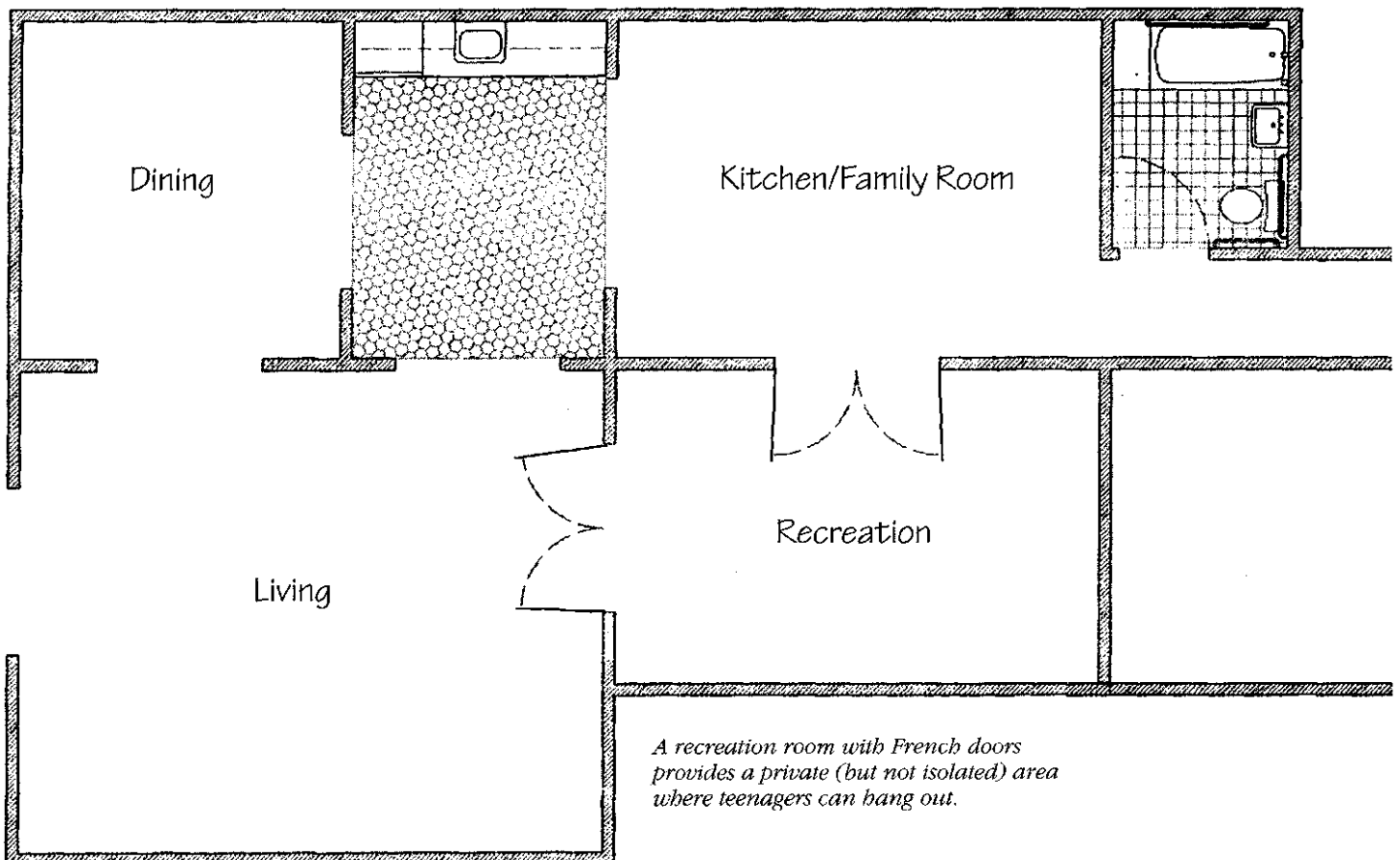

When it came to their homes, parents continued to make changes that would accommodate the needs of teenagers. Many of these modifications were similar to the ones other families made during the school-age years: families bought bigger wheelchairs, accessible vans, and hospital beds. They also installed ramps and built accessible exterior and interior doors and halls. Some parents who had the financial means added swimming pools and hot tubs. More families made their kitchens accessible so the child could be more independent. And there were continued efforts to make bathrooms larger, safer, and more accessible with special bath chairs, roll-in showers, hand-held shower nozzles, and accessible sinks.

Finally, workstations were created for school work. And for more independent and social adolescents, there was a need for accessible, semiprivate social space where teenagers could be with their peers and out of the watchful eye of their parents. One family specifically designed their new home so that the parents and the children could each have privacy without being isolated.

*“The house set-up is perfect now. Because of all of the modifications, my son can do anything and there is room for an aide to live upstairs when we are not around.”*

Parents described many different experiences and emotions associated with raising a child with a disability. Like parenting in general, no two situations are identical. This makes it hard to draw definite conclusions. However, we did see a trend which indicated that life generally became more difficult as the child developed. Social and emotional problems and issues with schools all surfaced or became more prominent. The impact of a non-supportive or inaccessible home became much more pronounced. Getting into and maneuvering around the house in a large power chair, climbing stairs, and bathing, lifting, and transferring a growing child all became harder as the child grew older.

However, the good news is that these are problems that can be solved, or

reduced, through accessible and supportive design. In raising a child with a disability, there are many things that cannot be changed. Fortunately, this does not have to apply to the physical environment. Your home can be modified to improve your child's safety, functional abilities, and independence. In the next two chapters, we will cover in detail exactly how this can be achieved.

## *Notes*

## Chapter 3

# Accessibility to the Home



Accessible design is the gateway to a safe and supportive home. All of our work with people with disabilities—both adults and children—has convinced us that the need for an accessible home cannot be emphasized strongly enough. Accessibility is vital both to your child and to you. For your child, it is the critical pathway that will allow him to function safely and at the peak of his abilities. For you, an accessible house can help ease the physical and emotional strains of parenting a child with a disability.

Generally speaking, it is better to develop a home modification plan now that will still work for your child and the equipment he will be using when he is fully grown. This can be particularly important if your child has a progressive condition. It is very uneconomical (and inconvenient) to modify an area several times. Whenever possible consult a physician or therapist to obtain an accurate prognosis and projections for your child's future abilities. Base your modification plan on that information and advice. And if it is obvious that your house will never be accessible enough, it is better to move if you have the opportunity. (If you have this option, do so while the child is young, before he forms strong friendships or starts school.)

### Creating an Accessible Home

Every family situation is different. Your ability to create an accessible home that works best for you and your child will depend on several key factors:

- **The first is the type and severity of your child's disability.** What portion of your child's body is impaired? Are the legs involved, the arms, or both? Will your child's condition become worse, or will it improve with medical treatment and therapies? Can you get an accurate prognosis? Does your child have intellectual limitations that affect memory or judgment? If so, special safety precautions may be necessary in your home, along with accessible design.
- **The second is the type of mobility device used.** Mobility assists, such as braces, walkers, manual and electric wheelchairs, scooters, and strollers come in all shapes and sizes. Your house should be accessible enough to accommodate a range of potential devices. Bear in mind that your child will grow out of one device and into a larger one as she develops. She may also need to use different devices for different functions during the same time period. Your home design should be flexible enough to accommodate all of these varied needs.
- **The third is the size, style, and site of your home.** Some homes are intrinsically more accessible, or adaptable, than others. A spacious, one-story house will be easier to make accessible than a split-level, raised ranch, or two-story house—all of which have multiple levels with connecting stairs between them. A house with an entry that is on grade, or nearly so, will be easier to access in a wheelchair than one that has multiple steps at the front door. Similarly, it is easier to use a wheelchair or other mobility device on a level piece of property than on a lot that is sloping, hilly, or uneven.

- **The fourth is your financial situation.** Accessibility is not free. In fact, it can be quite costly. And while financial assistance is possible in certain situations, it may not be available to everyone or to the degree necessary to complete the job properly. When doing your financial planning, remember that you will have to make adaptations to your home. Tax deductions may relieve some of this financial strain. Be sure to talk to an accountant when you budget your modifications.
- **The fifth is zoning approval.** This is usually required for ramps, porches and additions. Every community has rules on the amounts of space ("set-backs") that are required in the front, back, and sides of a house. There are also rules on the percentage of the property that the house and its appendages (garages, porches, landings, etc.) can occupy. If your proposed modification violates one of these rules, it may be possible to obtain a variance. This process is too complex to explain here. Talk to your local zoning official for advice.

### Accessibility Needs— They Are Everywhere

When your child is an infant or a toddler, chances are you will be able to carry him or her from your car and into your house without too much difficulty. However, as any parent will tell you (or as you already know if you have other children) the infant/toddler stage flies by very fast. Soon your child will be too heavy to carry without straining yourself. The situation becomes even more compli-

cated when your child starts using a mobility assist, such as a wheelchair, a special stroller, or a walker. These devices may be too large, cumbersome, and heavy to lift up steps, wheel across bumpy terrain, or roll through a door easily.

You will quickly realize that the need for accessibility applies to every area of your house. It starts at your driveway and continues up to your front door. It goes through the door and continues along your halls and your doorways. It goes into your kitchen, your bathrooms, and your child's bedroom and closets. It applies to your windows, doors, flooring materials, and light switches.

Accessible design also extends to your garage, your deck, or patio and even to your front and back yards. We will cover each of these areas in this and the following chapter. Again, because every situation is different, we cannot give you working drawings or explicit details on how to redesign your home. Instead, we will be providing tips, strategies, and general guidelines for creating accessibility. Our goals here are:

1. To increase your awareness of the importance of accessible design.
2. To demonstrate the scope of accessible design and how it applies to all areas of your home.
3. To encourage you to start thinking and planning for an accessible future.

One of the benefits of our consumer research is that we were able to identify modifications, equipment, and technologies that were successful as well as those that were not. We will share this information with you as well. In this way, you can learn from the experiences of other families and avoid some of the problems they encountered.

## The Driveway

Before your child comes into the house, he first has to reach it. This means the route from the car to the doors of your home must be accessible whether he is using leg braces, a stroller, wheelchair, scooter, or some other mobility assist. (Whenever possible also, there should be *two* accessible entrances to provide an extra exit in case of fire.)

Accessibility, therefore, begins at the front driveway (or entrance to the complex if you live in an apartment building or townhouse development). If you plan to have your child enter and exit your vehicle in your driveway, that portion of the drive should be level. The required size of this level section will depend on whether your child transfers from the car or uses a wheelchair lift in a van. (All lifts work better when they lead to level ground.) If the drive slopes too much, the wheelchair could roll down the incline if the brake is not applied immediately. Transition times (arrivals and departures) can be difficult with children with disabilities under the best of circumstances. If your driveway is level, you will not have the additional stress of worrying about a wheelchair rolling down the drive.

## Vans

Families whose children use wheelchairs often purchase vans or conversion vans that are customized for people with disabilities. Some conversion vans have wheelchair lifts and open interior space where the wheelchair is anchored or "tied down" to the floor. Vans can also have raised roofs and/or dropped floors, which are necessary if the child is very tall. Most



*Rear deck and ramp provide a second accessible entry and exit.*

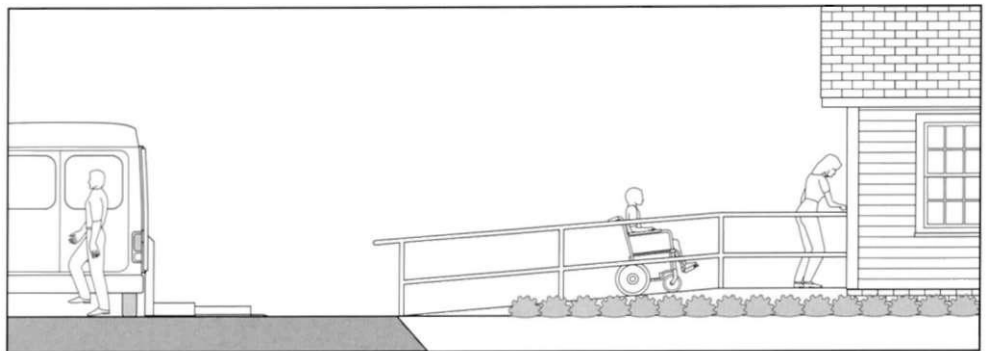

*A wide, flat driveway is essential when you have a van with a side lift.*





*Minivan with a side lift.*



*Full-size van with a side lift.*



*Conversion van with a raised roof.*

families bought their vans with lifts during their child's school-age or adolescent years. This is the time when the child becomes too heavy to transfer to and from the car. It is also the time when children frequently move to larger, power wheelchairs. Many of these chairs do not fold and it is difficult to fit them into a standard-size automobile or unmodified van. Every family in our survey who mentioned purchasing a van or a conversion van with a lift thought it was very important to make this purchase. They also rated the vehicles as being very helpful or effective.

### Design Considerations for Conversion Vans

Our emphasis in this book is on the home, not on vehicles. However, we are discussing conversion vans here because they often require special adaptations to garages and driveways. This is particularly true if the vans have a wheelchair lift. In addition to being level, driveways have to be hard-surfaced, smooth enough, and wide enough so that children in wheelchairs can enter or exit their vans safely and comfortably. Many of the parents in our study had to pave, repave, and/or widen their driveways to make this happen. (Asphalt and concrete are the most commonly used surfacing materials. It is difficult, if not impossible, to roll a wheelchair across dirt, gravel, grass, or pebbles.) The wheelchair lift can be either at the side or the rear door of a van. In either situation, larger driveways may be necessary to make room for the lift when it is extended and to provide the turning radius needed to get the wheelchair onto the lift.

Since the size of the vehicles and the length and width of the lifts vary, it is not possible to give precise driveway dimensions for every household. Your needs will depend on the type of lift that you are going to buy. However, there are some general guidelines to consider. Take the following scenarios, for example:

- **A minivan with a side or rear entry lift.** You must consider the width of the van (approximately 6 feet, 6 inches), the clearance necessary to open the front door on the driver's side (approximately 3 feet), the length of the lift that will project out from the van (approximately 4 to 4½ feet), and the space needed to turn the wheelchair or scooter onto or off the lift (approximately another 4 to 5 feet, depending on the size of the chair or scooter). Considering all of these factors, you will need a driveway width of around 19 feet.

- **A full-size van with a side entry lift.** The sizes of vans vary according to the make and model, which makes it difficult to provide exact dimensions. But to illustrate the difference, one leading manufacturer's conversion van is 2 inches wider, 23 to 35 inches longer, and 14 inches higher than their minivan.

For this type of van, a minimum driveway width of 19 feet will be necessary if you use a conventional lift.

If you purchase a side rotary lift, it will extend out only 3 feet and require no turning radius. In this situation, a driveway width of 13 to 14 feet should be sufficient.

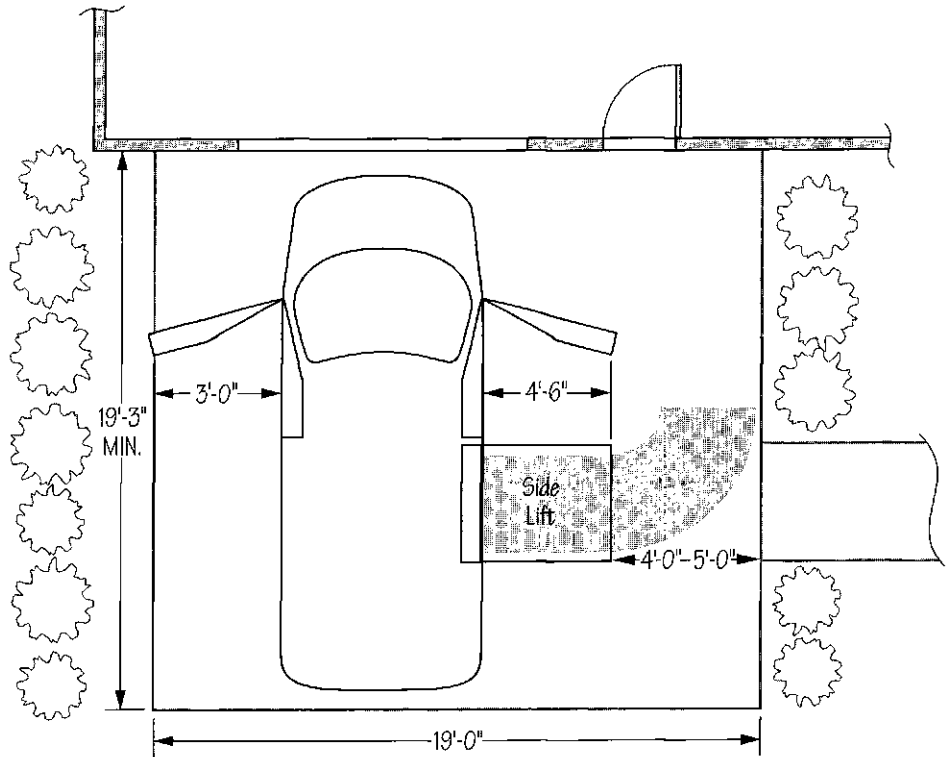

*Driveway dimensions for a full-size van with a side lift.*

- **A full-size van with a rear entry lift.** If you choose to purchase a van with a rear entry lift, the driveway requirements will be slightly different. For this vehicle, the driveway must be wide enough to accommodate the width of the van with both front doors open (approximately 13 to 14 feet). Built into this dimension is the width needed for the wheelchair to pass along either side of the van.

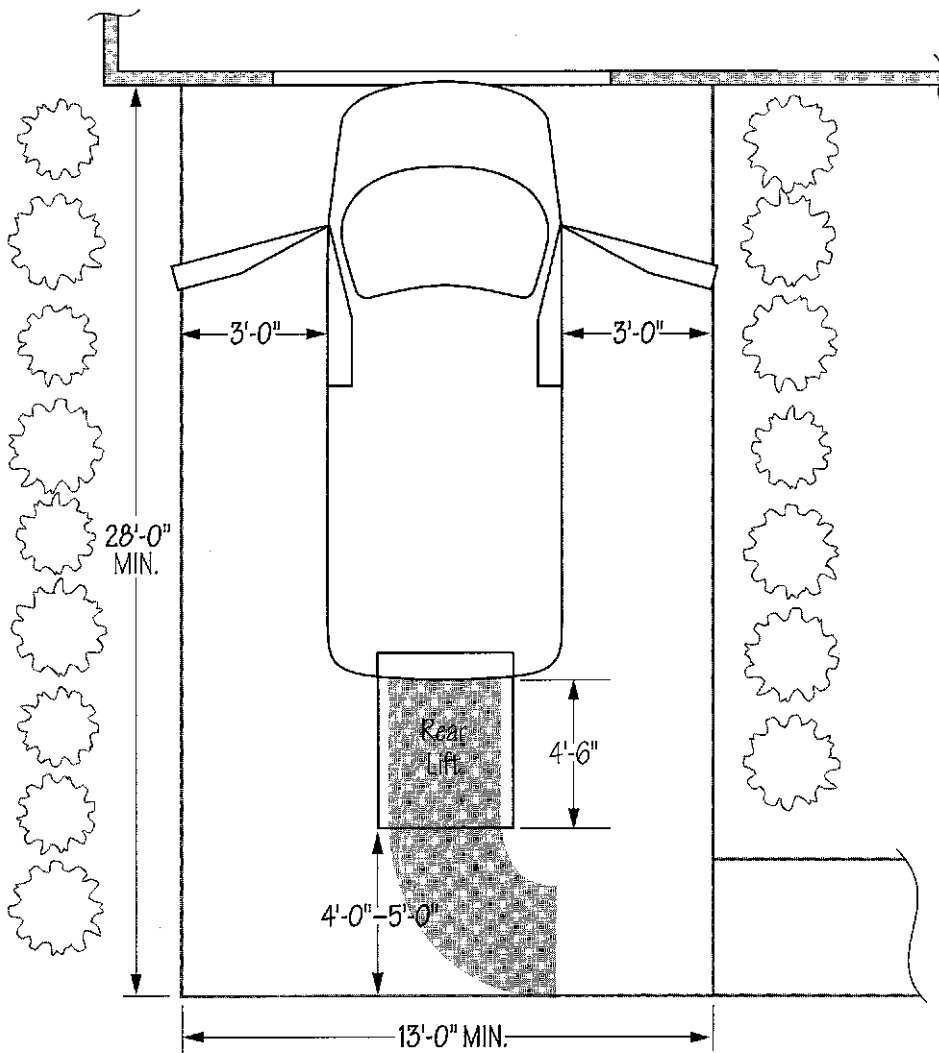

Driveway dimensions for a van with a rear lift.

### **"Tie-downs" in Vans**

These are very important. A person in a wheelchair should never be tied down with the long axis of the chair perpendicular to the long axis of the van. The length of the wheelchair should be tied down parallel to the length of the vehicle. The chair should be tied down in four separate places. For safety reasons, the child in the wheelchair is strapped down to separate tie-down points and not strapped to the chair. This system is called a 5-point tie-down. School buses are required to have 5-point tie-downs as well. If the van driver is an adolescent or young adult in a wheelchair, the vehicle should be outfitted with automatic chair tie-downs.

The driveway must be long enough to accommodate:

1. The length of the van (approximately 18 to 20 feet)
2. The length of the lift (4 to 4 <sup>1</sup>/<sub>2</sub> feet)
3. The space needed to roll the chair off the lift and turn around (4 to 5 feet)

A conservative estimate of the minimal level drive length for a full-size van with a rear entry lift is approximately 28 feet.

However, all of these turnaround spaces and widths may have to be extended if the child in the wheelchair must be reclined or have his legs extended.

Also, some people use portable tracks instead of a lift. Be extremely cautious with portable tracks. They tend to be very steep. The "tip over" point or ratio of rise over run for a wheelchair is 1:6 (for every one inch of rise, there is only six inches of run). The wheelchair will tip over at this or higher ratios of rise over run.

If it is physically or financially impossible to pave the entire driveway, you have two other options:

1. Pave the portion of the drive that extends from where the van parks up to the entrance to the house.
2. Construct a smooth sidewalk along the edge of the drive.

With this second option, you can pull your van up to the walkway, lower the lift onto the sidewalk, and roll the wheelchair onto or off the lift. Of course, the paved sidewalk must be wide enough for the



*A flat, level sidewalk provides an accessible receiving surface for a lift.*

wheelchair to turn and it must extend up to the door of the house.

The path from the driveway should be flat or gently sloped. It should be wide and paved with concrete or another smooth, continuous paving surface. Do not use rough-surfaced pavers because they create unpleasant vibrations and a bumpy ride for people in wheelchairs. Grouting between pavers that is too wide and/or not flush with the paving material can also create a bumpy ride and cause maneuvering difficulties for the wheelchair user.

### The School Bus

In addition to making your driveway large enough to accommodate a van, you may also have to consider the school bus. If your child takes, or will be taking, a bus to school or a day program, the bus may have to pull into your driveway to pick him up and drop him off. (This may be the case in rural and semirural areas.) Your driveway should provide enough width for the bus, the lift, the turning radius needed to get the wheelchair onto and off the lift and for the bus to turn around.

If the school bus parks in the street, you will need a flat sidewalk leading from the house to the curb. The lift will lower

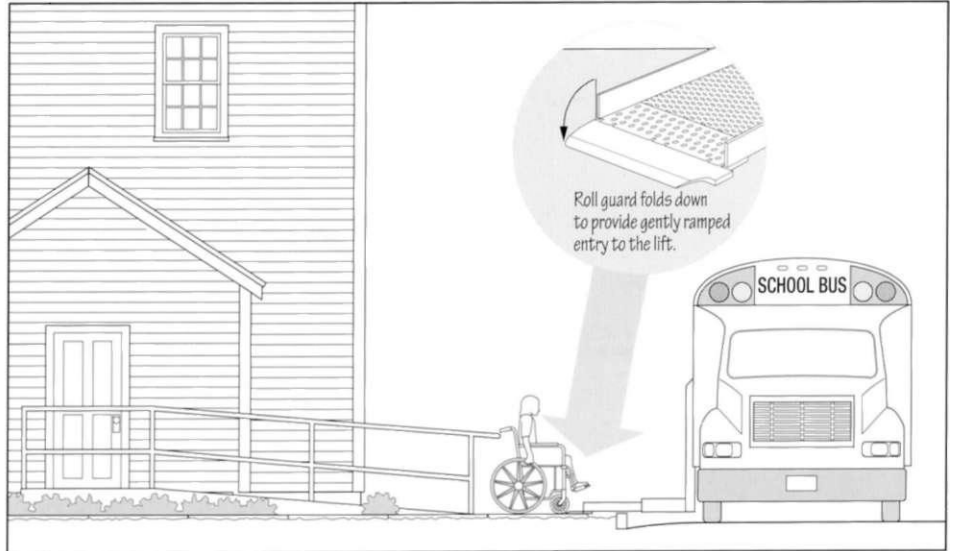

*A flat level surface is needed curbside or at the driveway for the school bus lift.*



*A wide smooth walkway will make it easier to roll a wheelchair around the property.*

onto the curbside end of the walk so your child can roll directly onto the lift. Sometimes the bus driver will pull up to the driveway and use the base of the drive for loading and discharging. In this situation the base of the driveway must be hard and level.

## Walkways

Concrete is one of the smoothest and most popular paving surfaces for walkways. However, one family in our study used pressure-treated wood decking to create a boardwalk along the side of their driveway that led to the front door and extended around the house. This made the entire property accessible. Since this house was in a beach community, weathered wood decking blended perfectly into the surroundings. Another family



*Wooden decking and smooth bluestone create visually interesting walkways.*

used bluestone set in concrete to achieve the same effect. These modifications both show that accessible design, when

thoughtfully and properly executed, does not have to look prosthetic or scream “disability.”

## Access Through the Garage

In bad weather, families in our study liked to do van transfers in an attached garage. The child then could go directly into the house from the garage. If you want to do this, you may need a higher ceiling in the garage and a taller garage door than normal, depending on the make of the van and whether or not it has a raised roof. Many full-size vans fit under a standard-height garage door but not all of them can. You will also need a much larger garage. Since it is illegal to have the

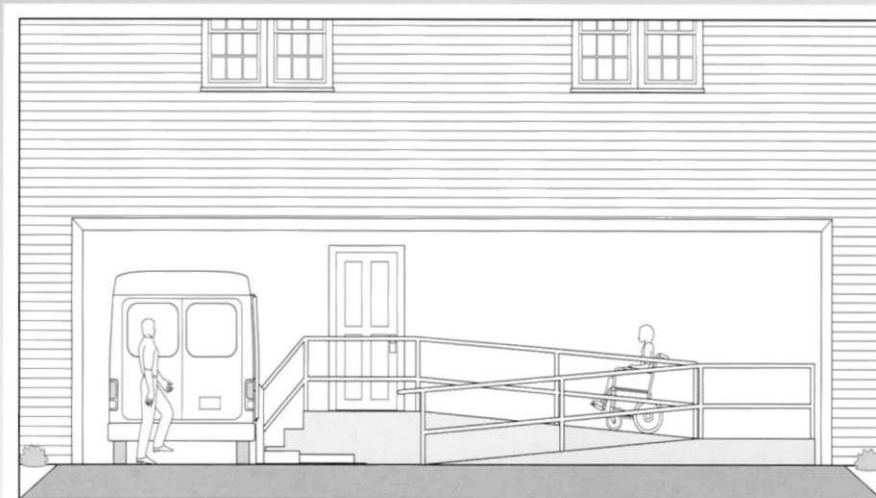

*An accessible garage entry will protect everyone from the rain.*

entry to the house at the same level as the garage floor, the door must be a minimum of 6

inches higher than the floor. A ramp from the garage floor to the door will be necessary.

## The Front Door

### Getting to the Door

Once your child and her wheelchair, scooter, or other mobility device are safely out of your vehicle and heading toward the entrance to the house, the first accessibility hurdle has been cleared. The next obstacle is getting up to the door. Very few houses are built without at least one or more steps at the front door. This creates an accessibility problem.

There are three ways to approach this problem. You can use:

1. Ramps
2. On-grade or level entrances
3. Lifts

### Ramps

***"The ramp made it possible for my daughter to come and go as she pleased."***

The most common practice among the families in our study was to build a ramp to the landing, porch, or deck. The majority of families constructed their ramps during the school-age years and adolescence, although some forward-thinking families built ramps during the pre-school years. Most families will eventually need a ramp, so this is a modification that should be made as soon as possible. Even if you can lift or carry your child fairly easily at this point, a ramp will save you wear and tear and strain on your back. It can also provide an early training ground where your child can learn how to use ramps.



*An attractive ramp (but it is missing a handrail on the right side).*

Ramps can be constructed using a variety of materials: concrete, wood, metal, and heavy-duty aluminum. (One of our families used bluestone to create a very attractive ramp.) Portable aluminum ramps can also be purchased. There are two versions of these. The truly portable ones are only effective for one or two steps, otherwise they are too steep. The other "portable" ramps come in sections and are attached in erector-set style. These ramps can mount a greater number of steps. They can be attached and then dismantled and moved to another location.

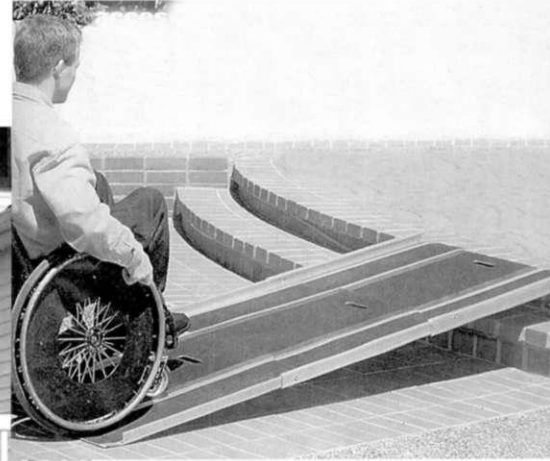

*Other ways to master steps in a wheelchair.*

Some families felt strongly that the main entrance to the house should be accessible. Since this is the entrance used by the rest of the family, the child with the disability does not feel like a "second-class citizen." Others did not like the esthetics of having a ramp in front of their house. If you also feel this way, you can disguise your ramp with plantings and landscaping, or have your child enter the house through a ramp in the garage, or build the ramp in the rear of the house. This last solution may increase the travel distance to the house, however.

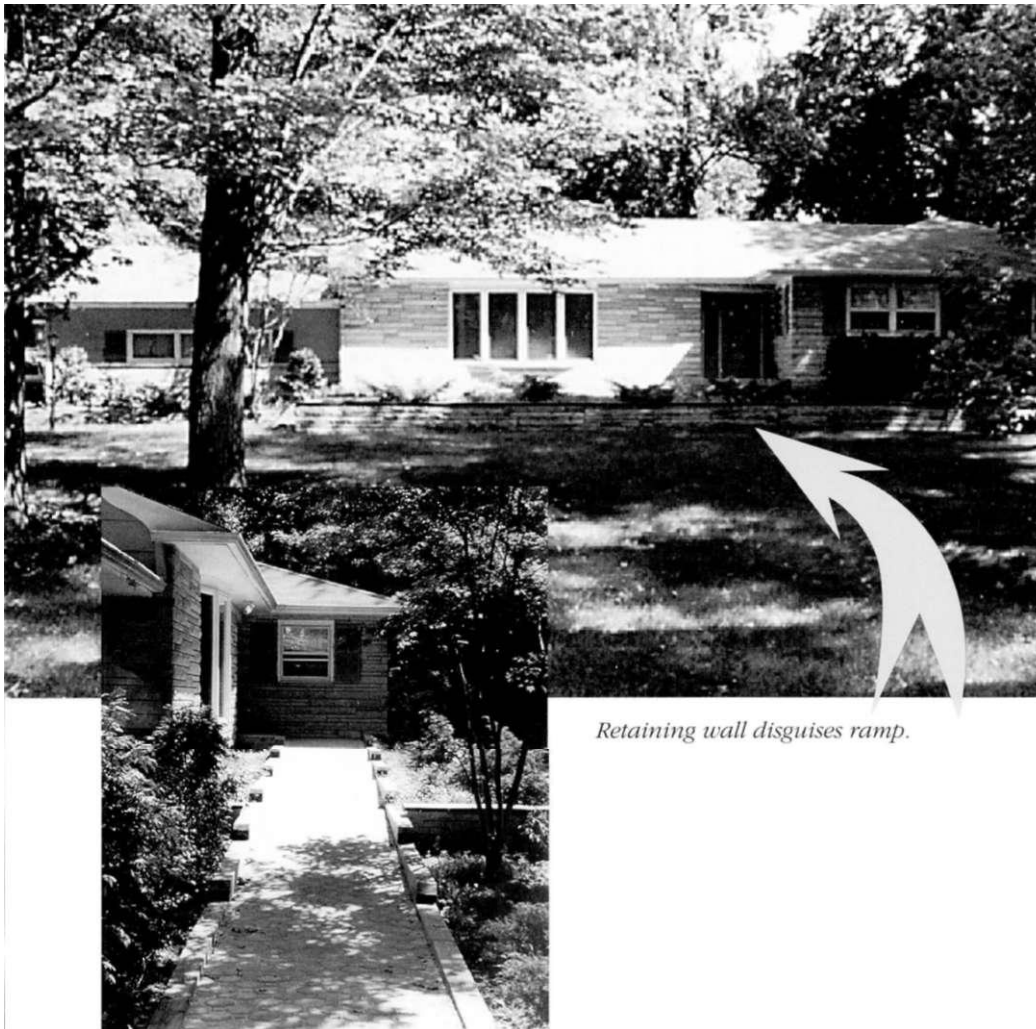

*Retaining wall disguises ramp.*

Because ramps will be the portal to your home for your child, it is important that they be carefully designed and constructed. Here are some general Do's and Don'ts about ramps.

**Do:**

- Follow accessibility standards.

For example: The maximum slope for a ramp is 1:12. This means for every one inch of rise, you need 12 inches of run. So a seven inch rise requires approximately a seven-foot ramp. (It is easier if you can do 1:14). You also need a level landing for every 30 feet of ramp. Good reference sources are the American National Standards Institute accessibility standard (ANSI A 117.1), the ADA Accessibility Guidelines, or the New Jersey Barrier-Free Subcode (NJAC 5:23-7) if you live in New Jersey. Be aware, however, that these are minimum standards that you should not go below. (See pages 100-102 in the Resource Guide for contact information.)

- Get a licensed architect to design the ramp and an experienced contractor to build it.
- Make sure the ramp is wide enough for a power chair. The recommended width is 36 inches clear between the handrails. However, if your child has uncontrollable arm and body spasms, you may want to make the ramp even wider so he does not hit himself on the railing when he is in spasm.
- If the ramp is going to make a 90-degree turn, the turning area must be level, with a minimum dimension of 5 feet by 5 feet. You will need *more* space if there is a 180-degree turn (a "switchback") or if



*A wide, level landing has been turned into a deck that the entire family can enjoy.*

your child uses (or will be using) a larger power chair, or a reclining chair, or if his legs must be extended. In these circumstances, some experimentation will be necessary to determine the correct size of the turning area.

- Remember, some doors open outward. Build a deep enough landing so your storm door or other out-swinging door can open with the wheelchair or scooter on the landing. The appropriate size for a level landing at the top of a ramp with a door is 5 feet by 5 feet, with 18 to 24 inches of clear space on the latching side of the door (a 24-inch space is recommended). The wheelchair will fit in this space and the door can swing safely past it.\*

*\*In one of our studies, the caregiver did not build a deep enough landing and the wheelchair rolled back down the ramp. He then had to place a wooden block behind the chair when it was at the top of the ramp. This held the chair in place while he opened the storm door, but it was inconvenient and dangerous.*

- Build more than one ramp, if possible. This is highly encouraged. Double exits may also be required by the building code or if the home is being funded by the Veterans Administration.
- Think about the future. Make sure your ramp will accommodate the larger and power-operated mobility devices that your child may need to use when he gets older.
- Consider a ramp with a heating element to melt snow and ice, and a roof or overhang to protect your child from the rain.

*“Our ramp was built in the back of the house and my child had to travel completely around the house to reach the front driveway or back door. This was a particular problem in bad weather.”*



*A ramp placed too close to windows that open outward can be dangerous.*

**Don't:**

- Don't make the ramp too steep.
- Don't overlook handrails. They are required by code on both sides of the ramp.
- Don't place the ramp under casement-style windows. You or your child could bump into them when they are open.
- Don't wait too long to act. Save yourself time and energy. Build the ramp sooner rather than later (but consider your needs for the future).





*Ramp with double handrails and two-inch bottom ledge to prevent caster wheels from rolling off the edge.*

- Don't skimp on landing width and depth at turning points (for 90-degree turns) and switchbacks (for 180-degree turns). Plenty of room is needed to turn certain wheelchairs, especially power ones.
- If you have both stairs and a ramp at an entrance, don't have your steps too close to the door. It could be dangerous maneuvering the wheelchair through the doorway if the front steps are too close to the turning area for the wheelchair. This will not happen if there is a level area 5 feet by 5 feet at the door.



*Ramp with stairs placed too close to the ramp and back door.*



*Attractive ramp but it is missing the ledge and handrail extensions.*

We have one last piece of advice on ramps. A common problem is that existing door platforms or landings are normally six inches below the interior floor level of the house. This prevents rain on the landing from coming into the house. If you build a ramp, its upper terminal platform must be level with the *interior* floor. This places the ramp above the existing landing. In many cases, the original stairs are unusable and a new set of stairs has to be constructed.



*Two examples of on-grade entries.*

### On-Grade Entrances

If the slope of the land is not severe, you can create a direct approach to your door with a sidewalk that rises gradually up to the doorway or front landing. You will have to regrade your lawn and walkway to do this. The families in our study who tried this approach all felt it was a very effective solution to the entry problem. There is no "special" entryway and the child with the disability can "come and go as she pleases" alongside family, friends, and everyone else.





*Outdoor lifts are particularly good for homes with small lots and insufficient room for a ramp. They can also be dismantled and moved to a new location.*

### Outdoor Lifts

A third way for your child to reach the front landing safely is with a mechanical platform lift. These lifts are primarily used in commercial settings but they are also made for residential use. The costs vary considerably depending on the number of steps up to the porch or landing and whether the lift is open or enclosed. Used or secondhand lifts can also be purchased for considerably less money. For example, the "Back in Action" Program of New Jersey Technology Assistive Resource Program (TARP) often has used lifts available at reduced cost. (See page 102 in the Resource Guide for contact information.)

## A Reminder

**Most modifications will require blueprints, review by the municipal building official, a building permit, and inspections. Though this may sound a bit overwhelming, doing work without a permit is not only illegal but can be downright dangerous.**

### Getting Through the Door

Now that your child is at the door, the next task is for her to pass safely through it. (Remember that you will need 18 to 24 inches of free space next to the storm door where the wheelchair can sit while the storm door swings past.) There are five stages involved in getting through the door:

1. Unlocking the door.
2. Opening it.
3. Getting through the width of the door.
4. Rolling over the saddle or doorsill.
5. Closing the door.

### Unlocking the Door

Unlocking (and locking) the door can be difficult for you if you are transporting your child in a wheelchair or other mobility device. If your child is older and more independent, she may need help locking and unlocking the door on her own. There are products on the market that can help both of you with this task.

You may want to consider:

- A keyless lock that will be easier to use.
- A remote control opener that your child carries or attaches to her wheelchair.
- An automatic garage door opener. (Of course, this is only effective if you have an accessible entry through the garage.)
- A door lock at wheelchair height (no higher than 48 inches).
- Key turners to help your child use her key.

*"We decided on a keyless lock so our daughter could safely enter the house without losing or dropping a key. Now we all love not carrying house keys."*

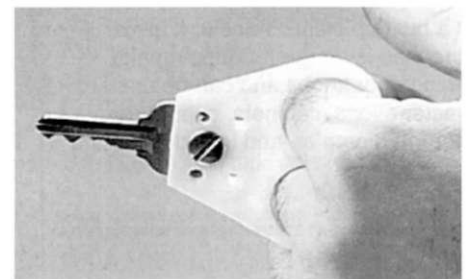

## Opening the Door

Once the door has been unlocked, it needs to be opened and entered. Opening the door can be easier with:

- Lever handles and extensions. Lever handles now come in a variety of designs that are attractive and easy to operate. Levers are recommended because they require less muscular strength and hand dexterity than traditional turning handles.
- Door knob turners and extensions.
- Door handles at wheelchair height.
- Power-assist doors, where the door automatically opens when a push-plate located near the door is pressed.



*Various types of lever handles.*

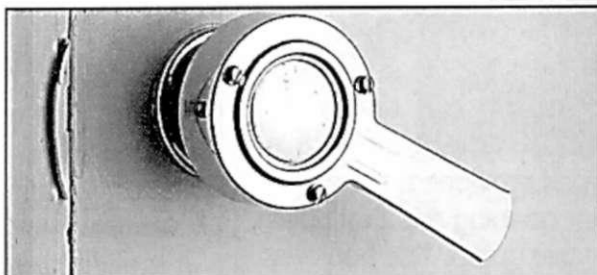

*Door knob turner.*

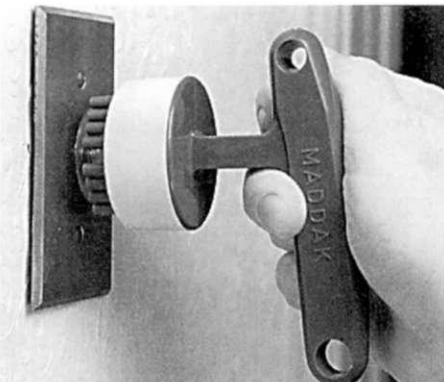

*Door knob extender.*



*Push-plate power-assist door opener.*

## Getting Through the Width of the Door

Moving the chair or other mobility device through the door can also be a problem. The ability to get through the door will depend on the size of the mobility device and the size of the door opening. Parents successfully solved this problem by:

- Installing double doors or doors that were wider than 36 inches.
- Using wide, sliding or large French doors (usually installed at entrances to decks and patios).
- Moving the doorway to a better location to avoid complicated or tight turns.



*Double doors create a very accessible entry.*



*Sliding doors create a wide entry.*

## Rolling Over the Doorsill

Parents dealt with the difficulty of having a raised threshold or door saddle by:

- Removing it altogether or using a saddle that was low and easy to wheel over.
- Adding mini-ramps on both sides of the door saddle.



*Doorway with minimal threshold.*



*Mini-ramp for rolling chair over doorsill.*

## Closing the Door

Automatic door closers are available but they must allow sufficient time for your child to get through the door. A simpler solution is to use a cord tied from the handle to the doorjamb. As your child passes through the doorway she can grab the cord and pull the door shut.

## Other Problems

Specific impairments or symptoms can also make it more complicated to enter or leave your house. For example:

- A child with severe arm or leg spasms could get hurt if his limbs flail against the door or doorframe when he is entering or leaving the house. Installing padding and an extra-wide doorway may help to prevent this.
- A child who must recline or use an extended leg rest on his wheelchair will need a greater turning radius on both interior and exterior sides of the door if there is not a direct approach—with no turns—to the door. These children will also need additional space at the latching side of the door.

These are some of the strategies that you can use—or your child can use—to get from the van or passenger car into your home. Of course, we did not discuss all the potential difficulties with this task, nor could we provide all possible solutions. We have simply presented an overview of the major accessibility issues involved with getting safely to and through an outside door. We also tried to suggest some design guidelines for you to consider, along with some product information that may be helpful. Now that your child is inside, let's look at some tactics for making the interior of the home equally safe and accessible.

## Chapter 4

# Accessibility In and Around the Home

Getting *into and out of* the house safely is an important issue for children with disabilities. But it is only the beginning step in creating an accessible home. Moving *around* the house safely, and as independently as possible, is just as important. In this chapter we focus on strategies for achieving this, with a detailed look at doorways, hallways, stairs, bathrooms, kitchens, and the outdoors. We end the chapter with some guiding principles on general accessibility throughout the home.

### Doorways

Getting through internal doorways and openings is another problem that will increase as your child grows. During the infant and toddler years, you will most likely be able to carry your child around your home. Even if your child is in a mobility device as a toddler, it will probably be a small-scale one that should fit through most doorways. However, as your child grows and moves into larger equipment—or learns how to operate this device on her own—navigating through

door openings will become more of a challenge.

Like the families in our study, you can meet the interior door challenge by:

- **Widening doorways.** It is difficult to consider doorways independently from the halls alongside them. Widening halls is very expensive, particularly if they have load-bearing walls. It is better to widen the doorways.

There is no set maximum width for a doorway. However, a **minimum width is usually 36 inches**. Again, the optimal width will depend on the size and type of mobility devices in use, the capabilities of the child in the wheelchair, the amount of open space on either side of the doorway, and the width of the adjacent hallway. If the hall is only 36 inches, the doorway will need to be 42-48 inches.

- **Moving doorways** to increase the turning space on both sides of the door.
- **Angling doorways.** This often makes the approach to the door easier by eliminating the need to make a 90-degree turn.



*The angled doorway (on the right) improves access to and from the bathroom.*





*Low thresholds (top) or the absence of thresholds (bottom and left) allow for smooth wheelchair travel.*



- **Providing space on the latching side of the door** so the child can open and pass through easily. For exterior doors, space is necessary adjacent to the latching side on both the inner and outer sides of the door.
- **Removing saddles** or thresholds.
- **Installing pocket doors or bi-fold doors** that can be opened and closed by someone seated in a wheelchair. (Be cautious with pocket doors! They can come off their tracks and their pulls can be difficult to use if the child has a hand problem. If bi-fold doors are poorly made or installed, they also may come off their tracks. Use only the best, easy-to-operate doors and hardware.)



- **Using dual swing hinges** so the door opens in either direction.
- **Purchasing "swing-clear" hinges** that increase the amount of clear opening.



The door opens and swings inward so the clear opening of the door is not decreased by the thickness of the door.

- **Installing power door openers.**
- **Attaching lever handles and handle extensions,** as shown on page 29.

**Most parents who modified doorways felt that these changes were very important and very effective. They made it easier for wheelchairs to get through doorways and helped children to move more independently around the house. All of the families who modified the doors in their homes did so during their child's school-age and adolescent years. However, we recommend making these changes sooner than that. This will prepare you for the effects of your child's growth spurts before they happen.**

## Hallways

In addition to making the doorways to rooms accessible, you must also consider how to make the passageways—or halls—that connect the rooms equally accessible. If your child is dependent, you should be able to move him through the house easily. If he is more independent, he should be able to move through the house with as little assistance as possible. Otherwise, you will be constantly "on call." This is not good for you or for your child. You will feel tied down and resentful. Your child will feel dependent and resentful.

If your home does not have an open floor plan, where one room flows into another, you may have to consider modifying your hallways. Or, if you are moving to a new home or building a new home, keep in mind that the halls will need to be accessible. Here are some tips for creating this accessibility or enhancing it in homes that already exist:

- In new construction, make the hallways wide. The exact width will, again, depend on the type of disability your child has and the type of mobility equipment he uses. However, a rule of thumb is that hallways should be at least 42 inches wide.



*Wide entrance hall and smooth flooring in a custom-built home.*

- Make the halls as straight as possible—avoid unnecessary jogs and turns that make it hard to maneuver a wheelchair.

- However, if there is a jog or a turn in your hall, consider angling or curving the wall at the corner. This will eliminate a tight 90-degree turn.



*Curved wall (above) and angled wall (right) can ease wheelchair turns.*



- Create sufficient turning radius to get into rooms, turn corners, or access closets.

### Controlling Access

If your child has poor muscular control or has an intellectual disability that affects her judgment, you may have to control or limit access to certain areas of your home to make sure she will be safe. In some situations access to stairs, doors, closets, hot water, stoves or cooktops, windows, wires, electrical outlets, and so on may have to be limited. This strategy is similar to the standard child-proofing that parents do for toddlers and pre-schoolers. However, the level of vigilance and control may need to continue all through childhood and into adolescence, depending on the type and severity of the disability.

- If necessary, try removing or relocating a closet, or moving a wall to increase the turning area at the door. (One family in our study removed a hall closet to make it easier to wheel their daughter into the

kitchen. Another shortened a bedroom closet to increase the width of the bedroom door so their daughter could wheel into her room independently.)

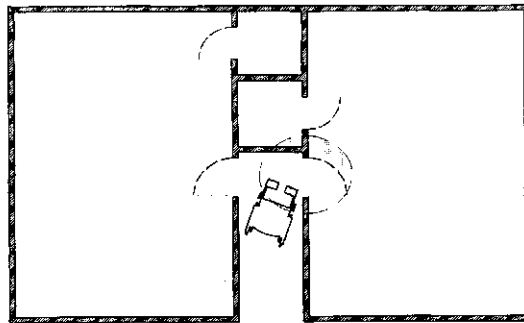

*Before*

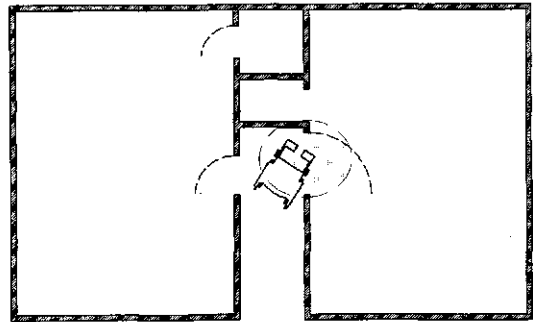

*After*

*Reducing the size of a bedroom closet can create space for a wider door.*

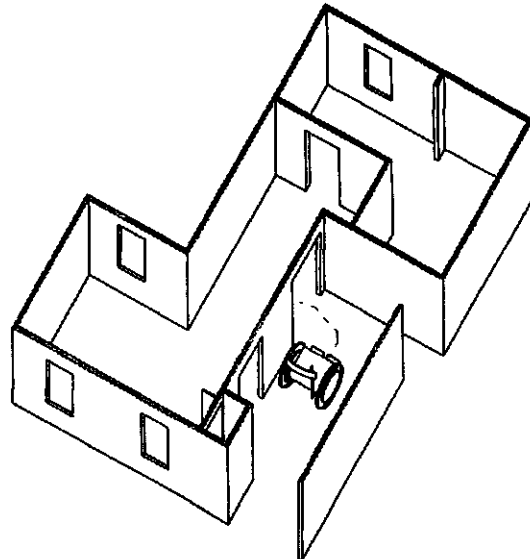
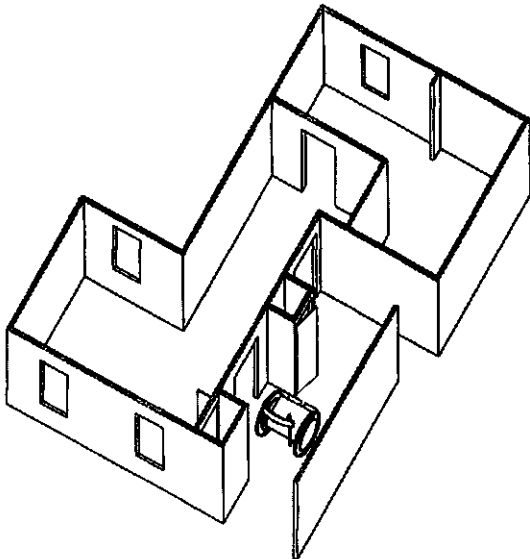

*Removing a ball closet increases the turning radius for a wheelchair, as does widening the doorway to 40-42 inches.*

## Damage Control

Many of our families described how wheelchairs and other mobility devices can scratch a wall, a door, or a door frame. This was particularly true when power wheelchairs and other large mobility devices were used. In some homes, this happened regardless of the width of the doorway. Parents developed some basic strategies for dealing with this problem. Their suggestions for how to protect the home:

- heavy-gauge wall coverings that are difficult to scratch
- carpeting extending 2 to 3 feet up the wall
- clear plexiglass panels installed on the wall where the problem occurs
- plastic corner guards along the door frame
- decorative molding at the appropriate height which can be pulled off and replaced when it gets damaged
- wooden wainscoting that can be patched, sanded, and repainted after it gets scratched
- kick-plates on doors
- carpet on the outside of an expensive spa tub to prevent the wheelchair from scratching the sides



*Plexiglass panel beneath window protects the wall.*



*Plastic corner guards cover a door frame.*



*Wainscoting protects walls from damage, while wide hallway makes wheelchair travel easier.*

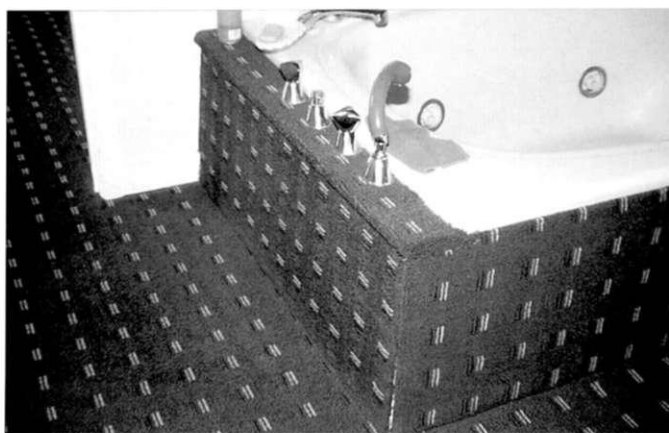

*Carpet on spa tub walls provides an attractive damage control device.*



*Attractive hardwood ramp eliminates step to a "sunken" room.*

## Interior stairs

If it is not practical for your child to live on one level, here are some strategies for "conquering" interior stairs:

- If you have a sunken living room or dining room, you will need to ramp the entrance to the room or raise the floor. (However, most houses will not have room for a ramp since one 7-inch step will need a 7-foot ramp, unless you build a steep ramp.)
- A flight of stairs can be mastered by someone in a wheelchair in several ways:
  1. A stair lift with a seat that your child can transfer to in order to ride upstairs. If you use one of these lifts, you will need to keep a wheelchair on each floor of the house.
  2. A platform lift that carries the child and the wheelchair up the stairs.
  3. Stair climbers that attach to a wheelchair and enable the child and chair to be pulled up the stairs by another person.
  4. An elevator. If you install an elevator, be sure to put in a telephone so your child can call for help if there is any kind of problem.



*Stair lift with seat.*



*Platform lift.*

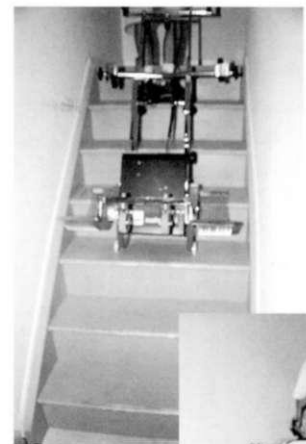

*Stair climber.*



*Residential design elevator.*

## Some General Things to Think About

A bathroom that seems to be a sufficient size now may not be large enough in the future. If that is the case, you will need to start thinking about constructing another bathroom. This leads to even larger questions:

- Can your present bathroom be expanded into an adjacent area of the house?
- Is there expansion potential in your house to build a completely new bathroom?

You should also consider where your child is sleeping. Does she sleep on the first floor or second floor? If she sleeps upstairs, you will need an accessible bathroom on this level as well (in addition to creating a way to get her safely up the stairs). Another option is to build an accessible toilet and sink area on the first floor and a full, accessible bath on the second floor. If these problems cannot be solved properly, you may have to take a much larger step and build an accessible addition, or start thinking about moving. You may feel that you have plenty of time for this, but time will pass very quickly. Make sure that any modifications that you do now will still work when your child is bigger. A totally accessible bathroom will help you care for your child or help her to care for herself at an earlier stage.

*“Accessible bathrooms made a big difference. Our daughter is not afraid of the bathroom—she washes her own face and hands and blow-dries her own hair.”*

## Bathrooms

It is hard to set priorities for accessibility and supportive design in the many areas of your home. The reality is that it is important for you and for your child to have your entire home accessible. We do realize that not all families have the financial resources to make this happen. In most households, priorities must be established. And it was very clear from our discussions with parents that an accessible bathroom was a very high priority. When we looked at the various areas of the house that families had modified (the entry, interior halls and doorways, the kitchen, the outdoors), the bathroom was the space that received the most attention. In fact, parents modified or bought equipment for the bathroom twice as frequently as they did for other areas in their home. There is good reason for this.

Bathing, grooming, and toileting are key ADLs (activities of daily living). The design of your bathroom and the equipment in it will have a direct impact on your ability to care for your child. This impact will grow proportionately with the size of your child. While bathroom accessibility is not generally a major problem when children are young, small, and quite portable, the situation alters drastically by the school-age years.

## Access and Basic Layout

Before your child can bathe, toilet, or brush her teeth (or before you can assist her with these tasks), she first needs to be able to get into the bathroom. And once inside, she has to get to the sink or transfer to the toilet, the tub, or the shower. This can present quite a challenge for a child in a wheelchair or other mobility device.

If you have a young child, now is the time to evaluate your existing bathroom very carefully. Ask yourself: Will this bathroom work, or can it be adapted so it will work for us in the future? Here are some specific questions to explore.

**1. Is the doorway wide enough for a manual or power wheelchair or other mobility device to pass through?** As we noted earlier, the width of the bathroom door cannot be considered independently from the hall width. However, a general rule of thumb is that bathroom doors should be 36 inches wide. (The door opening must be wider if you have a narrow hallway or if your child uses a large power chair or has to be in a reclining position.) Do you have this width now or can you widen the doorway? And remember that unless you have a very large bathroom, the door must always swing out to increase turning space in the room.

**2. How does the approach to the bathroom work?**

- Do you need to make a 90-degree turn to get through the door?
- If so, is there enough turning space in the hall or the adjacent room for a wheelchair to get through the door?



Turning space outside bathroom door.

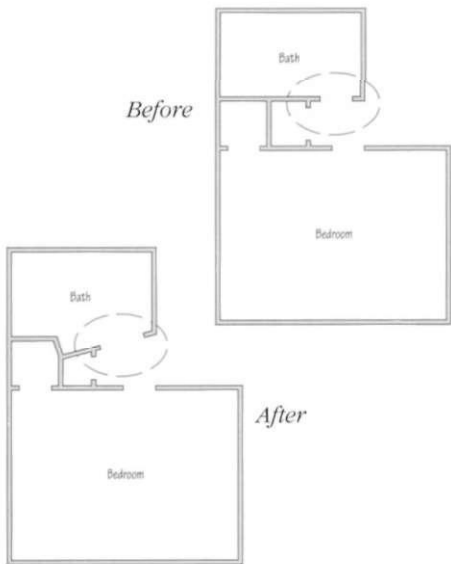

Angling a doorway can improve the approach to the bathroom. (The door should be 36 inches wide with swing-clear or offset hinges—or install a pocket door.)

Sometimes moving or reconfiguring a closet or angling the doorway can free up space to help you make the turn.

**3. How large is the floor area in the bathroom?**

- Is there sufficient room to move the wheelchair or a portable lift close enough to the tub or shower to make a transfer?
- Is there enough room near the toilet for a wheelchair transfer?

**Transfer space by the tub** generally depends on whether or not there is a built-in seat at the end of the tub. If there is, you will need to have the length of the tub plus the seat plus 12 inches beyond the wall at the seat end of the tub (approximately 93 inches) by a 30-inch width. Without the built-in seat, you will need the length of the tub (approximately 60 inches) by 30 inches.

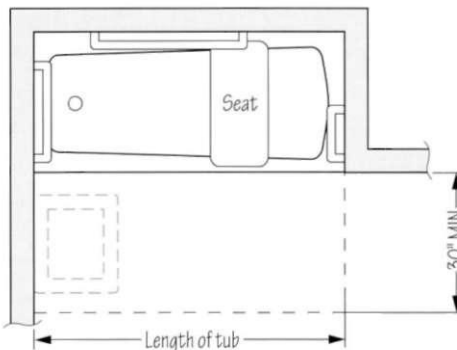

Transfer space by tub without built-in seat.

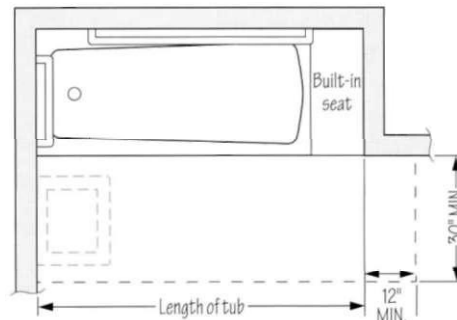

Transfer space by tub with built-in seat.

**Transfer space by the shower**

depends upon whether your child will roll in or transfer into the shower. Roll-in showers require an adjacent space of 60 inches by 30 inches. (For obvious reasons, a roll-in shower cannot have a "lip" at its entrance. There are units designed with "barrier-free" water stops that prevent the shower water from flooding the bathroom.) If your child will be transferring from a wheelchair onto a shower seat, you will need a space 48 inches by 36 inches alongside the shower.

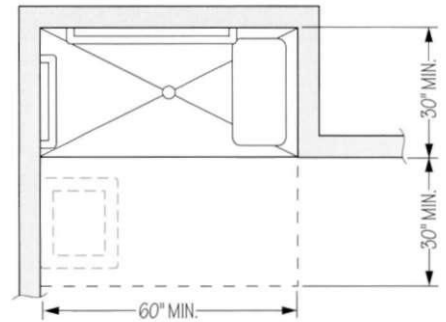

Transfer space by roll-in shower.

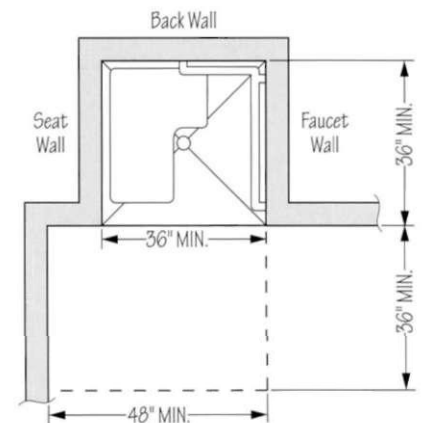

Transfer space by transfer-type shower stall.

**Additional transfer space at the toilet** may not be needed if your child can transfer diagonally (on an angle) to the toilet. If your child must transfer laterally or transversely (a side-by-side transfer), you will need the toilet located in a minimum 5-foot-by-5-foot space with the center line of the fixture set 18 inches out from the adjacent side wall. There should be 4 feet by 4 feet of clear space in front of the toilet.

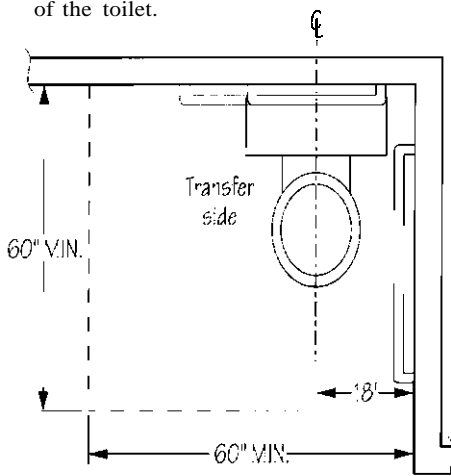

*Transfer space for a lateral transfer to toilet.*

**4. Is there enough room in the bathroom to turn the wheelchair around?**

While all situations are different, a rule of thumb is that 5 feet by 5 feet of clear space is needed for turning a wheelchair around. You will need more space if your child uses a "sip and puff or chin-controlled chair. You will also need more space if your child's legs must be extended. Some experimentation will be necessary.

**5. If there is not enough room to turn the wheelchair around, can you have two entry doors and a pathway through the bathroom?**

This approach can also improve privacy if one of the entries is in a hall and the other is in the bedroom. Make sure both doors swing outward.



*Spacious bathroom allows wheelchair to make 360 degree turn.*

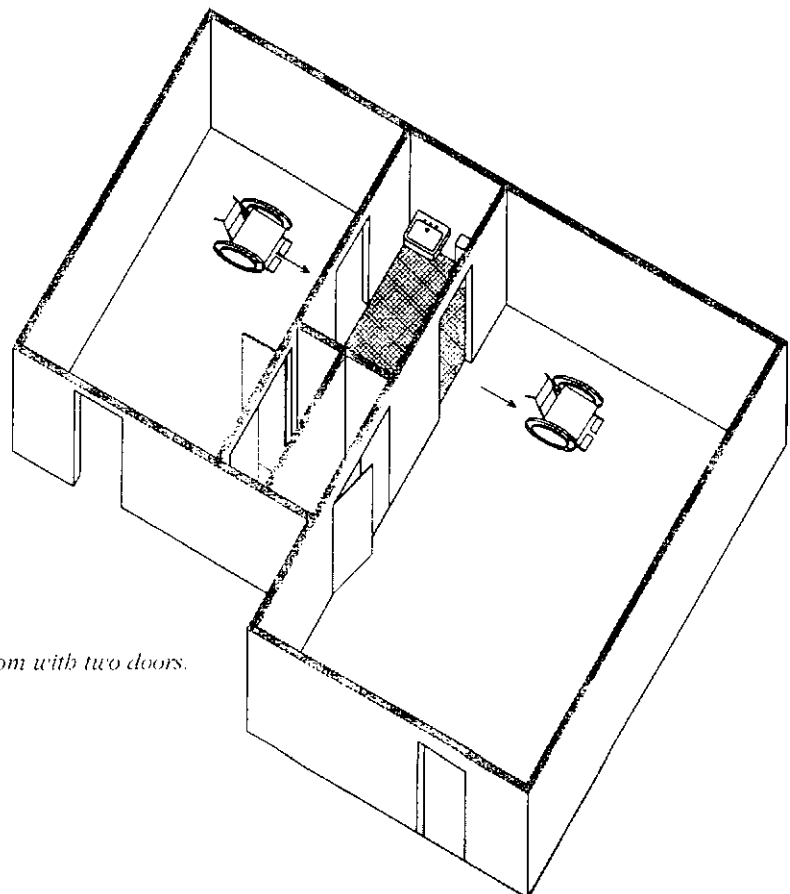

*Bathroom with two doors.*



## Steps for a Diagonal Toilet Transfer

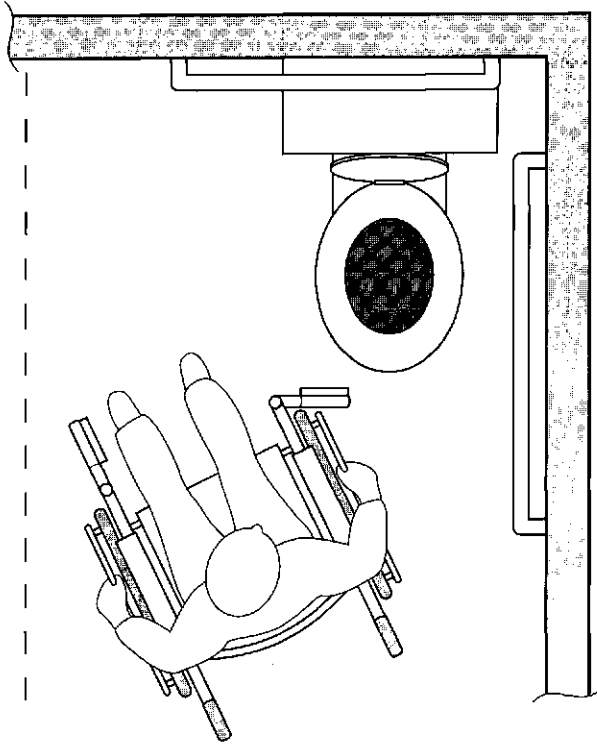

*Diagonal Approach 1*

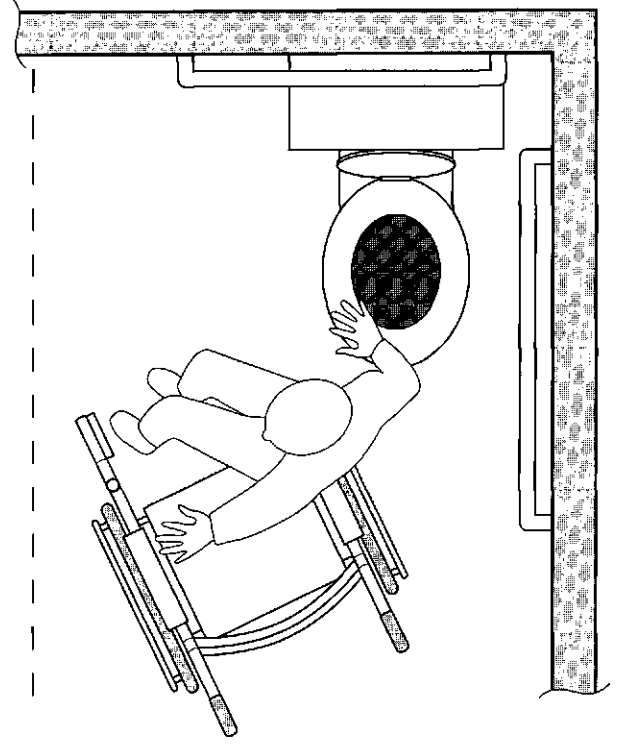

*Diagonal Approach 2*

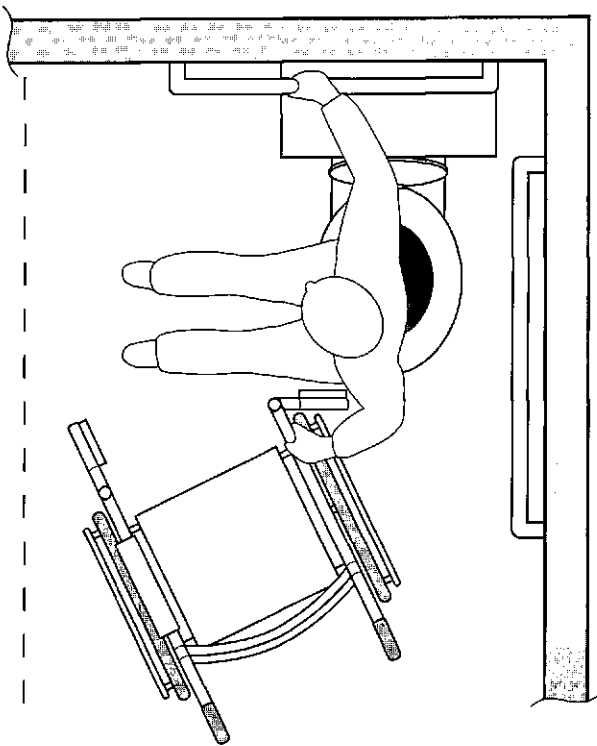

*Diagonal Approach 3*

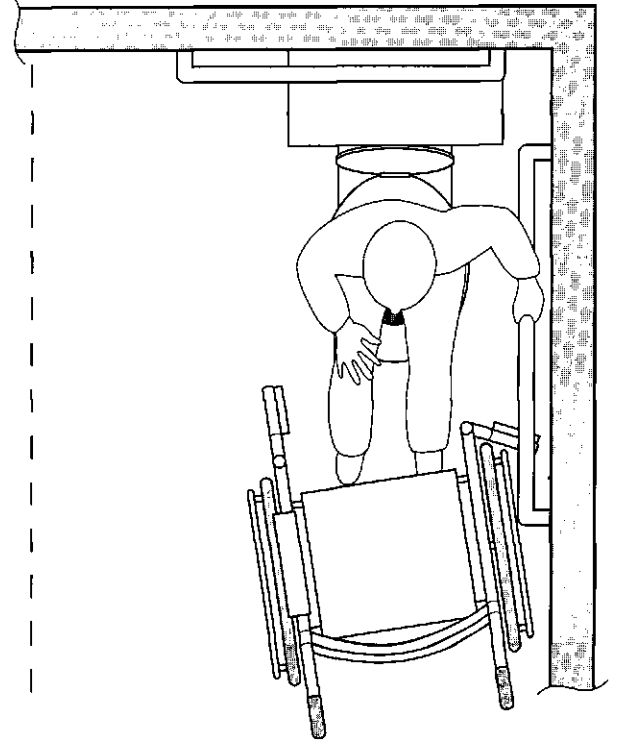

*Diagonal Approach 4*

## Steps for a Lateral (Side-by-Side) Toilet Transfer

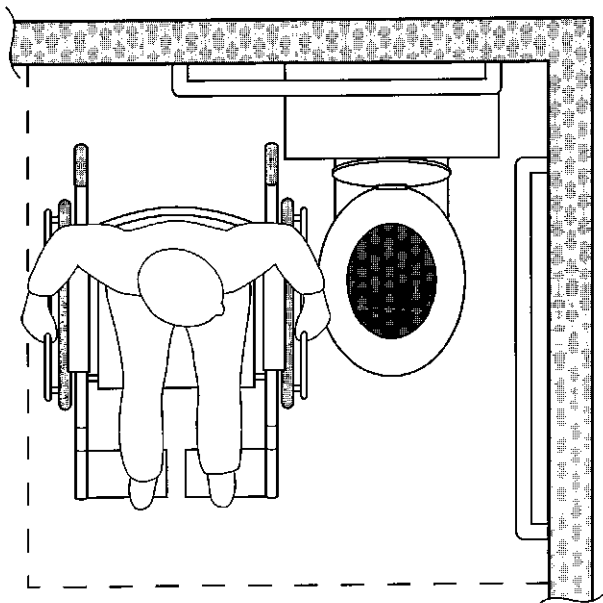

*Side Approach 1*

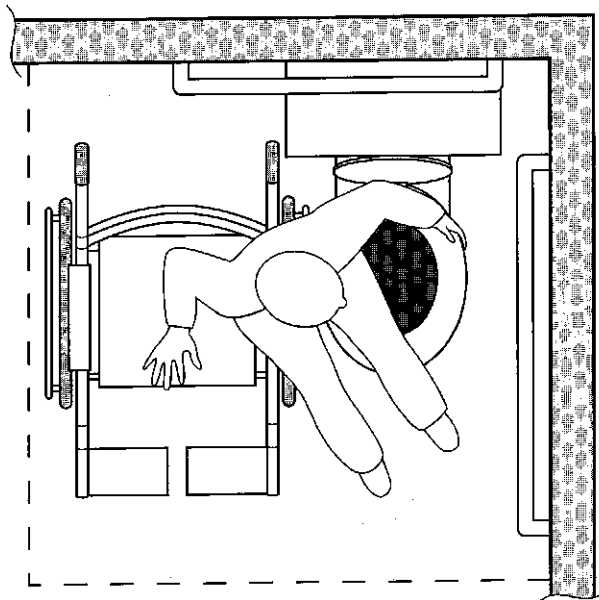

*Side Approach 2*

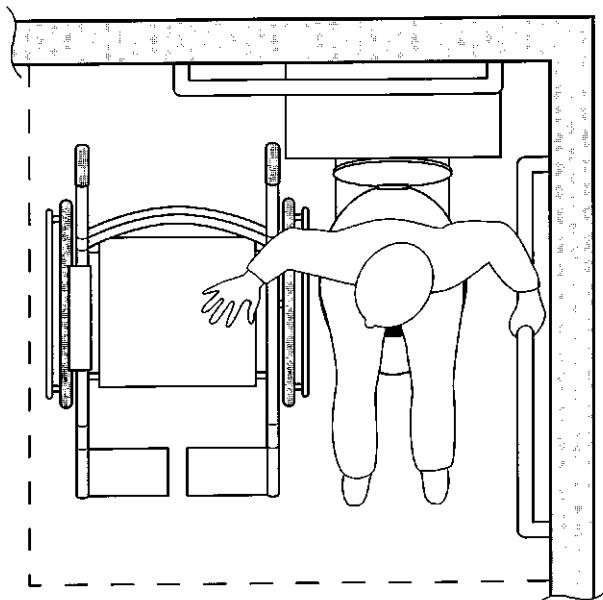

*Side Approach 3*

**6. If your child will not be using a toilet, is there enough room for a changing table that can eventually accommodate a full-size person?**

**7. Can a wheelchair fit under the bathroom sink?** The bottom edge of the sink must be higher than the arms of the wheelchair (approximately 30 inches).

**Grab Bars**

In addition to space requirements in your bathroom layout, you will need to **install grab bars** if your child is able to use them. They will help him transfer and provide support while standing up. Grab bars now come in a wide variety of shapes, sizes, colors, and materials. Explore what is on the market. Ask other parents and your health care professionals for advice about the types that will work best for you and your child. Grab bars should be installed in all areas of the bathroom—alongside and inside the tub and shower, adjacent to the toilet, and near the sink. Do a test run with your child and have him practice using the tub, the shower, and the toilet to make sure that the bars are installed in the right place. Also, make sure that they are installed *into the wall studs* by a professional builder or home remodeler. These illustrations adapted from the ANSI A 117.1 standards will give you some guidance on where to place grab bars most effectively. *But bear in mind that these standards were developed for adult males and will probably have to be adapted to fit your child's needs.*

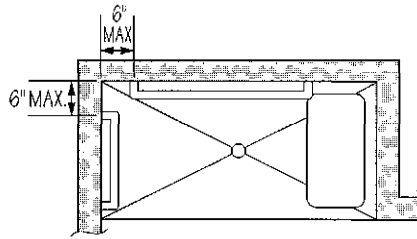

*Grab bars for roll-in shower with permanent seat.*

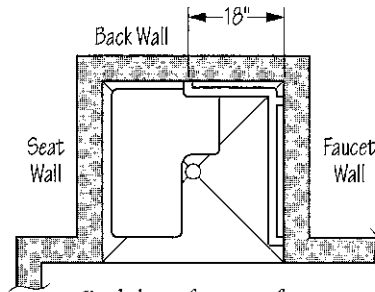
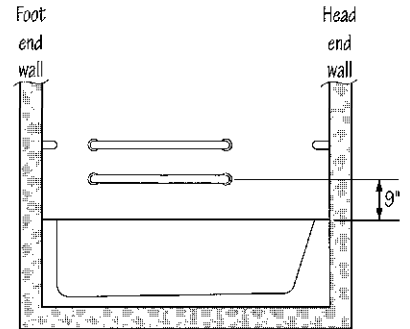

*Grab bars for transfer-type stall shower.*

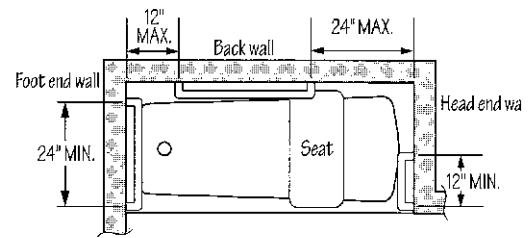

*Grab bars for tubs with portable seats.*

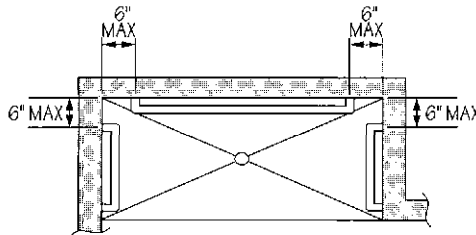

*Grab bars for standard roll-in shower.*

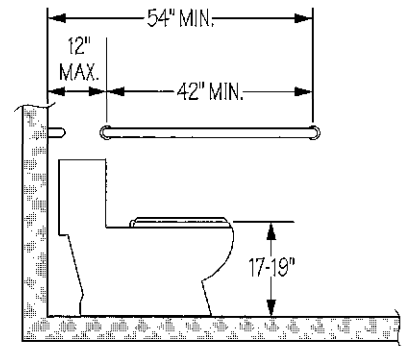

*Grab bar for side wall of toilet.*

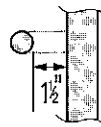

*The maximum distance between anchor wall and grab bar is 1 1/2 inches.*

These are just some very basic considerations for your bathroom. Keep in mind that as your child and his equipment grow bigger, you will need more space.

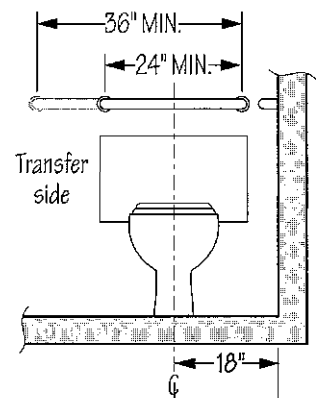

*Grab bar for rear wall of toilet.*

## Bathing Problems

Parents started out bathing their small child in the kitchen sink, kiddie tub, or in a regular tub with a special bath or infant seat. But as the child grew bigger, bathing became increasingly harder. Here are some of the problems that parents described:

- The child outgrew the sink. She then had to be helped into the tub.
- The child could not sit up in the tub. She needed to be held or supported.
- The child became too big for the tub.
- The child could lie in the tub, but had to be lifted in and out.
- As parents aged, they found it difficult to bend over the tub. Years of constant caregiving left some parents with bad backs.
- As the child grew bigger, it became harder to lift her onto a bath chair.
- If the child had a seizure, she became limp and impossible to hold up.
- If the child had problems with spasticity, the tub's fixtures and hard surfaces were dangerous for her flailing limbs and head.

Parents dealt with these and other problems in all the many ways described in this chapter—by modifying and enlarging their bathrooms, building new ones, and buying a variety of specially designed appliances and equipment that made it easier to keep their children clean, safe, and healthy.

### Bathtubs and Showers

There is a lot of equipment on today's market that can help with bathing and showering. It includes bath or shower chairs, bath or shower lifts, hand-held shower nozzles, special tubs, and roll-in shower stalls. The pre-school and school-age years are the time to start thinking about purchasing or installing these assistive bathing devices.

### Bath/Shower Seats

The most commonly used piece of bathing equipment in our study was a bath or shower seat. More than two-thirds of the families had purchased at least one of these seats. As with many of the assistive devices for people with disabilities, there are a bewildering number of bath/shower seats available, offering a wide variety of features.

Without knowing your child and your home situation, we cannot make specific recommendations for you or show you examples of every type of chair. But we can show a few examples that represent the different types of shower and bath chairs. We can also alert you to the following bath chair options before you make your selection:

#### 1. Height

- A low chair will allow the bath water to surround your child. This may be more fun or comfortable for him. However, you will have to bend over to wash him, so a low chair will be harder for you.
- A higher chair will relieve some of the strain on your back but it will mean you have to use a hand-held shower head, and your child will not be fully covered by the bath water.

#### 2. Material

- A metal, aluminum, or PVC (polyvinyl chloride) frame with a mesh or netting seat will allow the water to come through the seat.
- A metal, aluminum, or PVC frame with a vinyl-covered cushioned seat will be softer to sit in.

### 3. Position

- Some chairs sit completely in the tub or shower.
- Some chairs require an upright position while others let the child recline.
- Others extend out ("cantilever") over the side of the tub and may be easier to transfer to.

### 4. Degree of Support

This can vary among:

- A simple, armless bench or seat
- A chair with armrests
- A chair with arm- and headrests.
- A chair with foot rests
- A chair with a safety belt that will hold your child in place. (This is important if your child is spastic or is unable to support himself in a seated position.)

### 5. Movement

- Stationary. This is a regular chair or seat that does not move.
- Movable. The seats on these devices move up and down mechanically in the tub. Most of these seats are powered by water pressure. If you are considering one of these bath chairs, make sure the seat swivels sideways. This will make it easier to transfer from the wheelchair. Also, decide how far down into the tub you want the seat to go.
- A wall-attached shower chair. These seats can be stationary or move up and down manually. There should be an armrest that folds down to allow for transfers from a wheelchair. The height-adjustable ones have the advantage of adapting to the growing height of your child.

- Wheels. Some chairs have wheels so you can place your child in the chair in his bedroom and then roll him into the bathroom. With a wheeled shower chair you can also roll your child directly into a shower instead of carrying the child into the shower and then placing him in the seat (and lifting him out). Sometimes you can wheel these chairs directly over the toilet as well, assuming they have a cutout in the seat.

There is considerable variety in the bath/shower chair market. Think through your needs. Consult your physician, or your occupational or physical therapist. Realize that you may have to buy several different chairs over the course of childhood and adolescence. As your child grows or his degree of disability shifts, another type of seat may be required. Many of the parents in our study used several different chairs depending on their child's changing size and functional abilities.

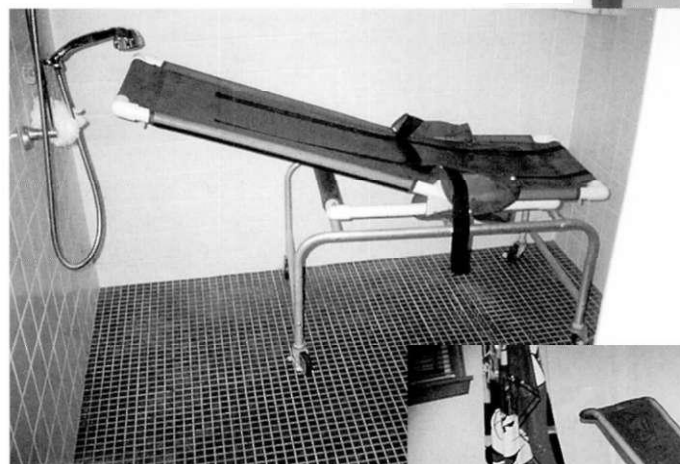

*Various types of shower chairs.*



As your child continues to grow and bathing becomes more difficult, you will probably have to consider a more aggressive approach to bathing. Here are some more technologically sophisticated ways for you to clean your child or to help him bathe and shower independently.

### Bath/Shower Lifts

If your child's disability or level of strength prevent her from self-transferring to a tub or shower seat, or if she is too heavy for you to pick up, you may need a bath or shower lift. There are several options for lifts:

- **Overhead lifts that move along a track on the ceiling.** Some families installed tracks that started over their child's bed, crossed the bedroom, and ended in the bathroom. The child was placed in a sling, attached to the track at her bedside, and rode to the bathroom, where she then transferred to the toilet and/or the shower seat. (If you opt for this approach, bear in mind that you will have to remove the headers over the doorways to accommodate the track, the cable for the sling, and the upper portion of the sling.) Sometimes these lifts even extended into living areas, such as television rooms.



*Header over door is partially removed to make room for overhead lift track.*



*Overhead lift and swing seat.*

- **Portable lifts that roll into the bathroom.** This may cause some problems with transferring to a tub seat. The legs of the lift cannot get under the tub to achieve the required stability. The seat on the lift must be directly over the four legs of the lift or the device will topple over when the child is lowered into the tub.



*Space underneath tub for legs of lift keeps the lift balanced.*

One solution to this problem is to raise the tub off the floor and create a space underneath it that the legs of the lift can roll into.

With some lifts, steel plates are available that can be attached to the floor. The legs of the lift are then bolted to the plates. This anchoring prevents the lift from tipping over when the seat swings over and the child is lowered into the tub.

## Hand-Held Showers

This is a very important accessory that will make bathing/showering easier. All of the parents in our study who installed hand-held shower heads felt that they were very effective. These devices have a number of benefits:

- Some hand-held units have shower massage capabilities which can be pleasant and therapeutic.
- With a hand-held shower head, the water moves around the child. The child does not have to move around or under a stationary shower. This gives both you and the child more control. If you are bathing the child, it should also keep you from getting soaked.
- The child can sit in the tub and shower or rinse off easily.
- If you are bathing your child in a tub, rinsing him periodically with warm water from the hand-held shower will keep his upper body warm.
- Some children will be able to use a hand-held shower independently. If your child has hand and arm strength, coordination, and control, he will be able to reach the shower head and rinse himself. Make sure your child can reach the controls to regulate the water flow, temperature, and pressure.
- A hand-held shower head will also help you, or your child, to rinse hard-to-reach areas of the body.
- A hand-held shower head allows you to move the water source away from the body very quickly if there are fluctuations in the water temperature. This will prevent your child from getting burned. A "pause control" to stop the flow of water is another desirable feature.

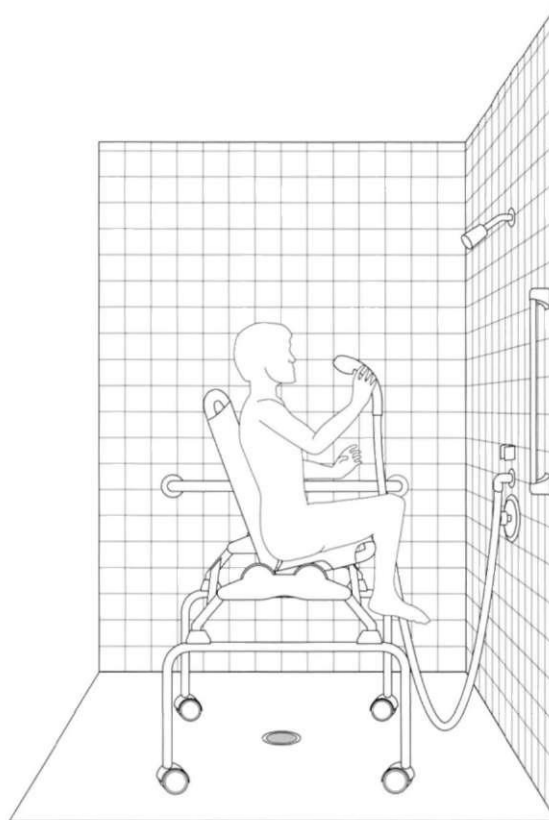

*A hand-held shower head is an important bathroom accessory.*

## Other Considerations

- The height of the bracket for the hand-held shower head is crucial. It must be low enough to be reached by someone in a wheelchair and high enough for members of the family who can stand upright to use it like a regular shower head. This is an inherent conflict. Some families solved this problem by building large showers with separate stationary and hand-held shower heads. You can also purchase units that have two heads in the same fixture—a high stationary head and a lower hand-held one. Another unit has an adjustable-height shower head that slides up and down along a vertical bracket.
- If the temperature controls (mixers) are not on the hand-held unit, make sure they are placed conveniently and safely on the wall of the shower. You may want to do a test run with your child to determine the best location for them.
- Constant temperature ("knife blade") mixers and anti-scald valves are a must.



*Adjustable height shower head slides along vertical bracket.*

- In *any* situation, you should not have to reach through the hot or cold water to get to the faucet controls. In new construction, shower valves are located "offset" so that they can be reached from the outside. Installing an anti-scald device is also a good way to prevent burns. This is particularly important if your child is spastic. An arm or leg in spasm could flail out and hit or kick the hot water valve and scald the child.

In addition to bathing equipment, such as chairs, lifts and hand-held shower heads, there are also bathroom fixtures that can be purchased to help you bathe your child or help your child to wash himself more independently.

*"Our tub was raised by at least two inches and a ceramic tile ledge was built so she could transfer from the wheelchair to the tub safely."*

#### Special Bathtubs and Showers

There are a variety of bathtub options available for children with physical disabilities. Some of the products that the parents in our study used included:

- **Oversize tubs.** These units provide sufficient room for the child to lie down in the tub. They are also large enough to hold a bath chair.
- **Raised tubs.** Because the floor of these fixtures are higher than normal tubs, they decrease the amount of bending that parents have to do when they bathe their child and lift her into and out of the tub.



*Wide ledge along side of tub helps with transfers and provides place for a parent to sit.*

- **Wide-ledge tubs.** These units have a wide ledge along the side and or the top of the tub. The ledge provides a place for the child to transfer to. The child can then ease down into the water from the ledge. The wide ledge also provides a place for the parent to sit while bathing the child.
- **Inflatable cushions.** The child sits on these cushions in the bath. The elevated height makes it easier to reach her.
- **Side-open tubs.** These fixtures have a door on the side of the tub that slides open and closed. When the tub is empty and the door is open, the child can transfer directly from her chair to a built-in bath seat. The door then closes mechanically and the tub fills with water. When the bath is finished, the tub water drains, the side door opens, and

the child can transfer out. Some units have vents that blow warm air onto the bather. The air keeps the bather warm while the tub is filling or emptying. These units can be quite effective, but they are costly.

- **Whirlpool or spa tubs.** These tubs provide a whirlpool movement of water that may help to relax muscles. Several families in our study installed whirlpool or spa tubs for this reason. They also felt that these tubs were nice for the entire family. If you have the space and the financial resources for this investment, you may want to consider a whirlpool



*Side-open tub.*

tub. Check with your medical team to see if your child could benefit from using one. If so, ask about any safety precautions that should be taken while the tub is being used.



## Shower Stalls

You may realize at some point that a bathtub or a shower-over-the-tub arrangement just does not work for your situation. Some families found that a standard stall shower large enough to accommodate a shower chair worked well. This may be the only option you have if your bathroom is small. It is also possible to install a prefabricated shower stall that has a removable "lip," so you can roll your child directly into the shower. In addition, there are now units with flexible water dams that a wheelchair easily rides over.



*Shower stall with "lip" removed (top) and in place (bottom).*



## Roll-In Showers

In other homes, where space allowed and the level of disability required it, families constructed large, roll-in showers (generally 5 feet by 5 feet) that had no lip. Every family who installed a large shower felt they were very important and very effective modifications. If you don't have room for a large roll-in shower, you can replace your existing tub with a shower stall.

Roll-in showers have several advantages:

- They are easier to get into. They will allow you to roll your child, or allow your child to roll himself, directly into the shower and then transfer to a shower chair.
- or*
- You can transfer your child to a rolling shower seat first and then wheel the seat into the shower.
- or*
- You can roll the wheelchair up to the side of the shower and transfer your child directly from the wheelchair onto a built-in or portable shower seat.
- If your child needs assistance with washing, a large shower will allow you or another caregiver to move around comfortably in the stall using the hand-held shower head.

Some parents also felt that large roll-in showers gave their child more independence and dignity. The child could reach things and shower on his own. They also were safer—less slippery than a tub, and both easier to get into and roomier than a tub or standard-size shower stall.

For this type of shower to work, you will need either a pitched floor that slopes down to the drain or a floor that slopes up from the rest of the bathroom and then back down to the shower. These designs direct the water to the drain without flooding the rest of the bathroom.

In addition, make sure you have a storage shelf or rack for soap, shampoo, conditioner, etc., right by your child's place in the shower. These toiletries should always be within easy reach. You do not want to let go of your child to get one of these items. If your child is able to shower independently he should be able to reach everything he needs from the shower seat.



*Shower floors slope down toward drain (top); mini-ramp goes up and down into shower (bottom).*



*Plastic shelves on casters in the shower provide easy access to toiletries.*

## Problem Alert!

Changes in the bathroom can be "big ticket" items. It may be helpful to know about things that did not work very well. Here are some of the devices that parents bought and then had problems with:

### 1. Bath/shower chairs

- Inferior construction—the chair fell apart.
- A hydraulic chair whose seat did not swivel—it was hard to transfer the child to the seat.
- A design that made positioning difficult—the parent had to hold the child on the seat.
- Unwieldy size—parents had to put the chair and lift into the tub and then remove them after each bath.
- Height—some parents complained about bending over too far if the chair was too low, and being unable to place the child in the bath water if the chair was too high. (Decide how you want to bathe your child before you buy.)

### 2. Grab bars

- Poor installation—they came out of the wall.
- Bad placement—the child could not reach them.

### 3. Whirlpool or spa tubs

- Insufficient depth—the water was not deep enough when the child grew.
- Water current—it was too strong and pulled the child under the water.
- Access—the design made it difficult to get the child in and out of the tub.

### 4. Tub lifts

- Sling movement—there was an insufficient amount of swivel.
- Sling height—it did not position high or low enough.

There is a tremendous array of equipment on the market. Products are being constantly refined or replaced by more user-friendly models. There is probably something out there that will be right for you and your child. But make sure you get professional advice before you buy. Bathing can be dangerous and your child's safety is at stake. Consult your child's physical and occupational therapists. Have your child try out the various types of lifts and seats to see how well they work. Be an informed consumer.

## Sinks

Wheelchair accessibility will also help you to groom your child or help your child groom herself at the sink. The closer your child can get to the sink, the easier it will be to wash her face and hands, brush her teeth, or comb her hair—or for her to do these things independently. There are several ways to create a sink area that is more user-friendly for people in wheelchairs. Here are some possibilities:

- **Wall-hung sinks** will provide room underneath the sink for wheelchair access, although space may be tight with a standard wall-hung unit. There are wall-hung fixtures with extended sinks that provide more room to position a wheelchair underneath the sink. However, they can break off from their wall mounts rather easily and are not particularly recommended. If you opt for an extended sink, make sure the spout extends far enough out over the sink for the water to be accessible to a child in a wheelchair. Similarly, the lever handles on the faucets should be long enough to reach from a wheelchair. You can also install the faucets on the side of the sink to make them more accessible.
- **Pedestal sinks** will also provide some level of accessibility. However, the pedestal may limit how close you can get a wheelchair to the water. Try these sinks out before you purchase one.

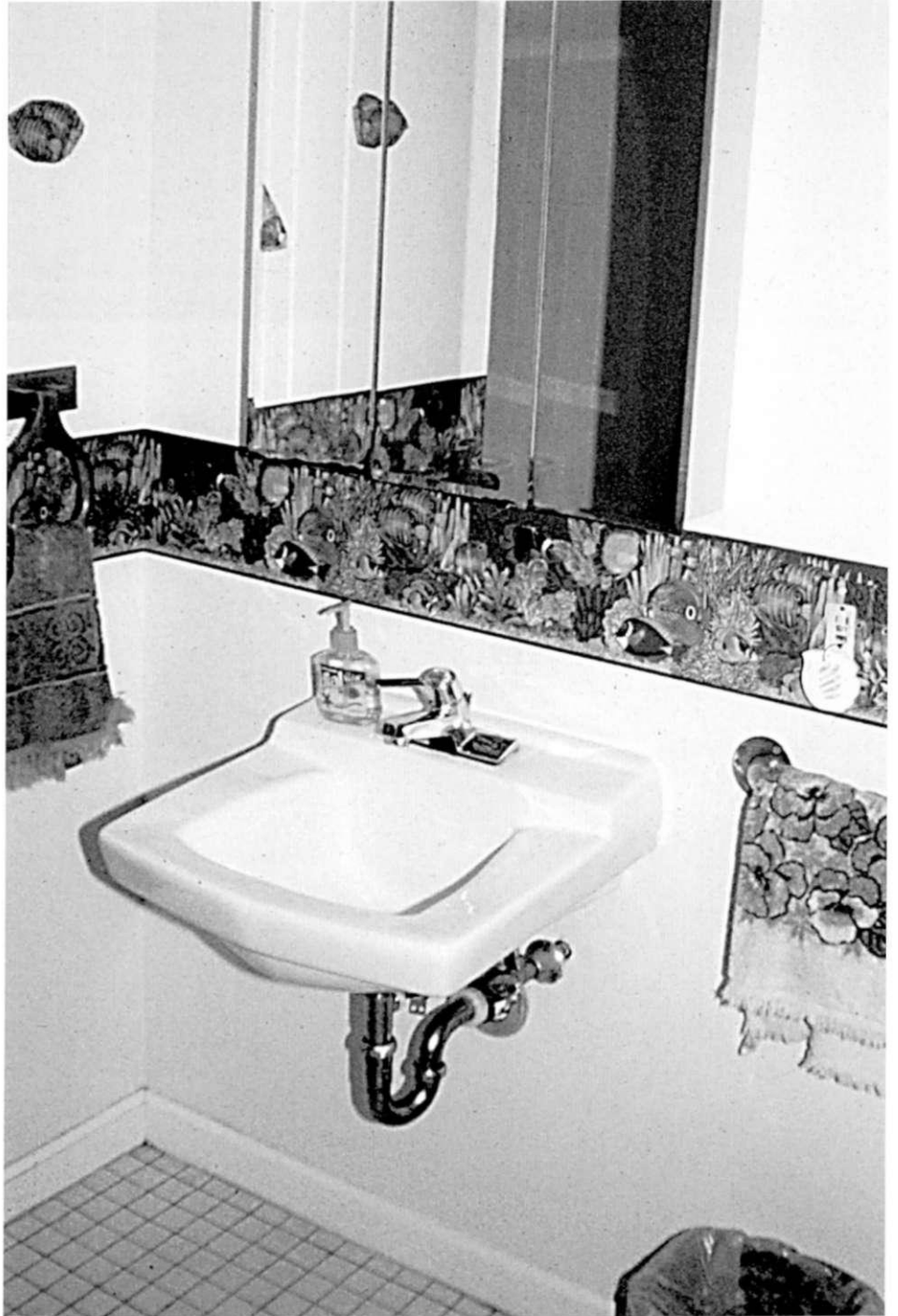

*Wall-hung sink.*

- **Drop-in sinks on a countertop** are quite effective if there is a sufficiently large knee opening under the sink. This will allow the wheelchair to roll directly up to and under the sink counter for easy access. If you have drawers in your bathroom vanity near the sink, make sure they are accessible. If your child has more ability in one hand, have the drawers accessible to that hand.
- **Adjustable-height sinks** are also available. These units, while costly, allow you to adjust the height of the sink to accommodate the various members of your family as well as the child with the disability as she grows. Some units come with hand-held remote controls that will make it easier for your child to control the sink height independently. Another option is to install a wall-hung sink and remount it periodically as needed. If you opt for this solution, make your waste line rather low to accommodate a low-hung sink. As your child grows, the sink can be raised and the drainpipe replaced with a longer unit. If you use flexible leads for the supply lines, they can be replaced when the sink is raised without any soldering.

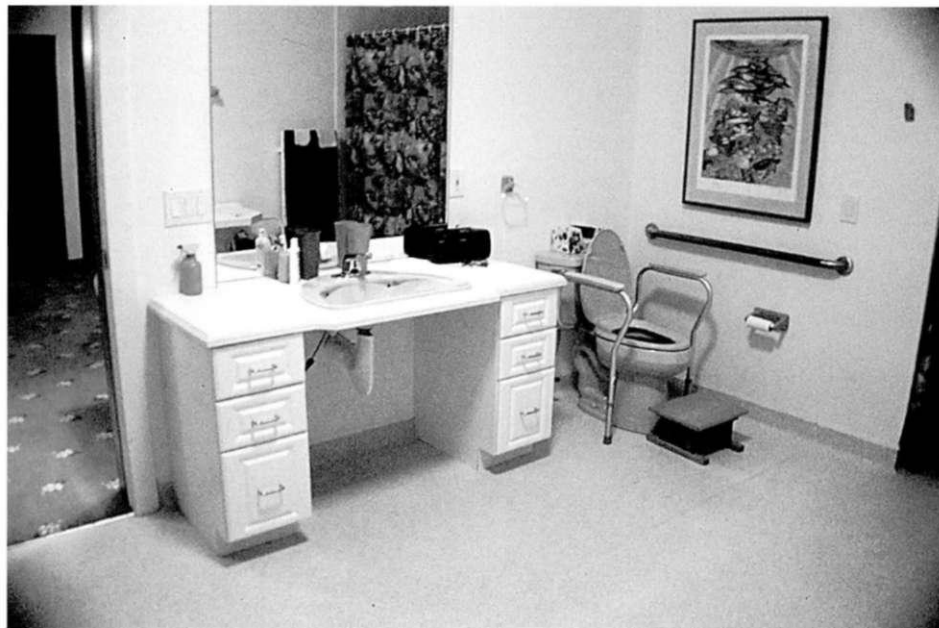

*Drop-in countertop sink.*



*Adjustable-height sink.*

#### Other Considerations

- **Sinks and countertops should be the appropriate height** for children in wheelchairs and other mobility devices. The standard for adults is 30 inches from the floor to the bottom of the counter. The desired height for your child will vary according to her size and the type of mobility device she is using. Try to plan for a full-grown child.
- **The pipes** in any wall-hung or drop-in sink should be configured close to the wall. This will provide more knee room for the child in the wheelchair. The pipes and drain lines should also be insulated so your child does not rub her legs on the hot water pipe and burn herself.
- **The amount of surface area available at the sink** is another important feature. Create a sink area with plenty of counter or shelf space. Everything needed to keep your child neat, clean, and well-

groomed should be immediately accessible. If your child can perform these tasks independently, she will need items such as soap, toiletries, hair and tooth care products, and cosmetics at her fingertips so she does not have to ask you for help.

- **Install mirrors** so the child in the wheelchair can see herself easily. Mirrors can be tilted from the top or can cover the entire area behind the sink. In either

case, the child in the wheelchair will be able to see her reflection as she brushes her teeth, fixes her hair, washes her face, or applies makeup. The standard height for mirrors is 39 inches above the floor. If you place a mirror significantly lower than this, water from the sink will splash onto it. Of course this dimension will vary depending on the height of the sink.



*Child in a wheelchair can see reflection with tilted mirrors over a well-lit sink.*



*Low mirror can be seen from wheelchair.*

- **Make sure that the area around the sink is well lit.** The light switch should have an easy-to-access dimmer that is installed at an appropriate height so your child can regulate light levels by herself.
- To avoid the possibility of an electric shock it is wise to have an electrician put the entire bathroom on a **Ground Fault Indicator (GFI) circuit**. If this is not possible any outlets close to water should be GFI.
- Any device that can be operated with a closed fist is considered barrier free.

## Faucets

Faucets for sinks (as well as showers and tubs) should be easy to operate and easy to reach. You should never have to put your hands through the water to turn them off or on. (This will prevent you or your child from getting burned.) Some faucet features to look for:

- Lever handles that can be operated by a hand, arm, or elbow and do not have to be gripped.



*Lever handles on sink faucet.*

- Easy-to-use mixing valve. A single lever faucet that controls both water temperature and volume is recommended.
- Spouts that come far enough over the sink to make it easy to reach the water from a wheelchair.
- A spout with a pull-out hose that brings the water closer to the child.
- Sensor-activated taps that turn on when they detect motion underneath the tap.
- Consider installing **anti-scald valves** that are thermo-controlled so your child does not burn herself.



## Helping the Child Get to the Toilet

When your child outgrows a potty or toilet chair, there are other options to consider. Many parents made their toilets wheelchair-accessible through a variety of strategies:

- Grab bars installed adjacent to the toilet that the child can grasp to help him transfer from a wheelchair to the seat. Remember to get grab bars installed professionally and anchored into the wall studs. Make sure the bars are in the most effective places. We saw situations where the grab bars were not easy to reach.
- Raised toilet seats that are easier to transfer to and from a wheelchair.

## Toilets

### Toilet/Potty Chairs

These were the most frequently purchased toileting assists. Parents purchased toilet/potty chairs in the early years. Most parents found the chairs made it possible for their children to use the toilet and, in some cases, to toilet independently.

There are a number of different types of toilet chairs on the market. Determine your needs by asking yourself:

- Do you (or will you) need a wide seat or safety straps so your child will not fall off the seat?
- Does your child need high back support?
- Can you use a seat that attaches to a regular toilet or do you need a free-standing one?

Check with your physical or occupational therapist for advice on the most appropriate type for your child.

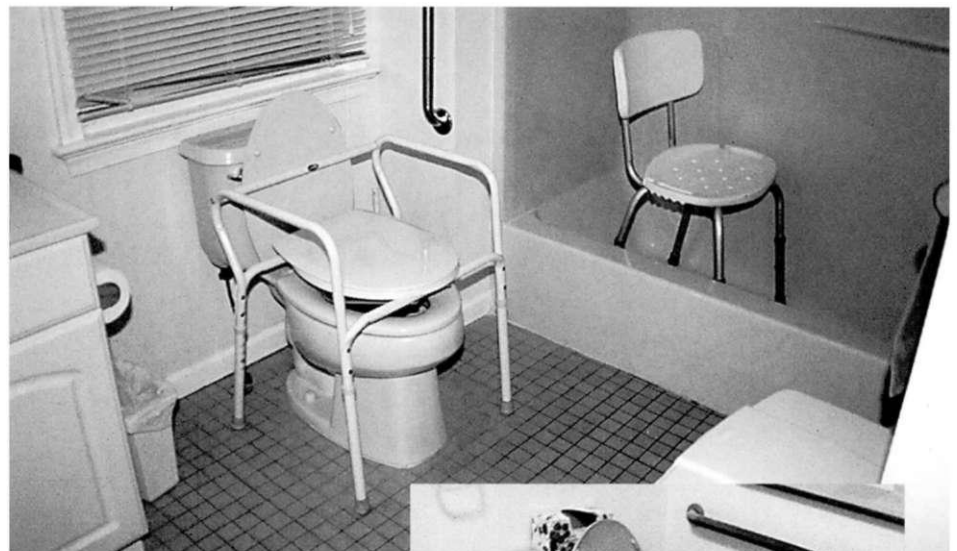

*Toilet chair sits directly over the toilet and provides a raised seat. However, vertical grab bar is not recommended for toilet transfers.*



*Portable grab bars fit around toilet. Horizontal grab bar is the best solution for toilet transfers.*

- Toilet seats with arm supports that may help the child get on and off the toilet and balance himself in the seated position.

Don't forget that you will need sufficient space next to the toilet for the wheelchair, as mentioned on page 49.

### Chairs That Roll Over the Toilet

These chairs provide back and arm support. They have a seat opening that lines up with the toilet, just above it. They are chair height so your child will not have to lower herself onto the toilet or lift herself off the seat. Some of these chairs can also be used in the shower.



*This chair can be used both over the toilet and in a roll-in shower.*

This is a chair with a toilet seat and a bucket underneath to collect the urine and feces. Parents bought commodes because they were portable and, in some cases, easier to use than a toilet. They also come with chest straps for support. Adjustable height legs allow the commode to "grow with your child."



*Commode with high back support.*

### Toilet Lifts

Lifts were discussed earlier on page 47. If your child cannot stand or transfer to a toilet and is becoming too heavy to lift you may want to consider a mechanical lift. Lifts can be either portable or ceiling-mounted. Don't forget that you will need sufficient space adjacent to the toilet for the lift as well as room to position your child onto the seat. The space suggested for lateral transfers from the wheelchair is 36 inches.

### Bidet

This is essentially a toilet-like fixture with hot and cold running water. The child (or adult) sits on the bidet and the water cleans their genital and anal areas. (Only two families in our study installed bidets but both felt they were very effective devices.) A bidet drains like a sink. It does not flush like a toilet so it cannot be used for urinating or having a bowel movement.

### Heat and Water Cleansing Apparatus

These devices attach to a regular toilet. They squirt water onto the anal and urinary areas following urination or a bowel movement. Heat then blows onto the area to complete the cleansing and drying. These devices are used by children who cannot wipe themselves.



*Heat and water cleansing apparatus.*



## Changing Tables

If your child cannot use a toilet, and never will, you should consider a permanent changing table in your bathroom (and perhaps another one in your child's bedroom). At some point, you will need a full-size table that can accommodate a young adult. The parents in our study who needed to use changing tables offered the following advice:

- Make the table large enough for the child to grow into.
- Make it high enough so you do not strain your back bending over. (One family bought a doctor's examining table which gave them the necessary height and size.)
- Have plenty of storage room for diapers, chucks, wipes, powder, etc., immediately at hand. You don't want to leave the child unattended while you grab a diaper from a closet.
- Install a heat lamp above the table to keep your child warm while he is undressed. (Heat lamps are also good for keeping your child warm while he is getting dressed after a bath or shower.)
- Consider installing an additional changing table adjacent to your child's bed. You can change your child and then slide him over and onto the bed.



*Storage cart on casters allows easy access to diapering supplies. Large changing table will not have to be replaced as the child grows.*



*Bed with adjacent changing table at same height.*

## Toileting Trials

The degree to which children with a disability can learn toileting varies considerably. Here are some of the situations parents described:

- The child did not have the cognitive skills necessary for toilet training and had to be in diapers permanently.
- The child could be only partially toilet trained.
- The child was able to develop a successful bowel program, or learn self-catheterization.\*
- The child was toilet-trained during the day, but wore diapers at night.
- The child could mostly toilet himself, but still needed assistance from his parents, special equipment, assistive technologies, or home modifications.

For different reasons, some children can find it difficult or impossible to use a toilet:

- Spasms make it hard to sit still.
- A child is simply unable to sit on a hard surface.
- The position of a child's legs can prevent him from sitting comfortably on the toilet seat.
- A child in a body cast cannot urinate or have a bowel movement lying down.
- Other children either can't sit up without support from someone else, or cannot get on or off the toilet unaided.

Major problems arose when the child could not be toilet trained at all because:

- He could not feel the urge to urinate or move his bowels.
- He had no control over toilet functions.
- He could not communicate when he needed to use the toilet.

We don't want to alarm you by implying that your child will have all of these problems, or even some of them. Every situation is different. However, if you know there is a possibility that any of these things may happen, you can be prepared for them.

## Ways to Help

In addition to the equipment and the design strategies we describe in this chapter, parents suggested some behaviors or treatments you can adopt to make things easier:

- Monitoring your child closely while she is on the toilet.
- Lifting your child onto the toilet (although this will eventually be bad for your back).
- Holding and supporting your child while she is on the toilet.
- Catheterizing your child (see footnote).
- Using pull-up diapers.
- Installing padded toilet seats.
- Training your child during the day, while using diapers at night.
- Buying dressing aids that will help your child do/undo her clothing by herself. (These can be "sticks" with hooks at the end that will help your child put on a garment, devices to fasten buttons and zippers, and aids to pull up socks and stockings.)
- Putting your child on a bowel training/toileting program.
- Considering surgical diversion options.

*\* Catheterizing is the process of removing urine from the bladder by inserting clean, flexible tubing into the urinary tract. The urine drains out into a bag or basin. If clean, intermittent catheterization (known as C.I.C.) is necessary for your child, your health care professional will teach you how to do it. When your child gets older, he may be able to do this on his own.*

## Kitchens

The need for an accessible kitchen is also one that develops over time. In your child's infancy and toddlerhood, of course, you will be preparing all his meals and snacks. Your main task will be to create a comfortable place to feed him. Your kitchen should be large enough to accommodate your small child's specialized feeding chair or a high chair comfortably (children generally eat in their wheelchair or mobility devices when they get older). If your young child is in a wheelchair already, then the table must be the right height for the chair or device to fit under it.

If your child is crawling or using a special walker or scooting board, the kitchen should be baby-proofed the way it would be for any toddler:

- Electrical outlets should be baby-proofed with covers.
- Sharp edges on counters or tables or low shelves should be covered with corner guards.
- Some parents also carpeted a portion of their kitchen floor so their child could crawl around comfortably.

Even the most spacious kitchens seem to shrink when the child gets bigger and the size of the equipment grows accordingly. The kitchen is frequently the "activity hub" of the house where everyone naturally gathers for meals, snacks, homework, or just to hang out. A decent-sized space will be necessary to accommodate the entire family comfortably.



*Spacious kitchen improves wheelchair access.*

Depending upon his abilities, your child may be moving more independently around the kitchen during the late school-age and adolescent years. He may also be starting to get snacks or prepare meals on his own. This opens up a whole new-world for both of you. Up until now, you have been actively using the kitchen while your child has been using it passively—that is, you have been preparing his food, making him snacks, and serving them to him. Now your child may want—and you may want your child—to do some of these things independently. Parents noted that they made nearly all the modifications or acquired special products for their kitchens during the school-age and teenage years.

## Fostering Independence

This new quest for independence in the kitchen can be quite scary for parents. It may seem easier (and less anxiety provoking) for you to just continue doing all these food-related chores for your child. If your child is ready, resist this urge. Think of it as the normal strivings for independence that all older children go through. The parents and children in our study advised:

*“Try not to be over-protective. Don’t treat the child as if he has a problem. Let him do as much as possible.”*

Encourage independence and normal behavior. Having said that, remember that the safer your kitchen is, the more you will be willing and able to let your child do things on his own.

## Basic Considerations

To create a safe and accessible kitchen, here are some things to consider:

- **Sufficient space for your child to move around comfortably** in his wheelchair or other mobility device. Some families in our study enlarged their kitchens and/or removed peninsula counters and pantries to increase the floor space. Others added accessible center islands with plenty of aisle space to make it easier for their child to cook.
- **Accessible countertops for food preparation.** These should be the appropriate height and have the necessary knee opening for the wheelchair to fit under. The standard is 30 inches from the floor to the bottom of the counter, but you may need them lower. Countertops can be adjustable (from 28 inches to 36 inches high) to meet the specific needs of your child.



*Kitchen supplies stored on accessible countertop are within easy reach of person using a wheelchair.*



*Easily accessible open shelving.*

- **Open shelving that can be easily reached** from a wheelchair for frequently needed items (although this can be a problem in a house with toddlers and young children who may pull things off the shelves).



*Wheelchair-accessible countertop is built into center island.*



- **Pull-out drawers, shelves, cutting boards, and counters in cabinets for storage** that can be easily accessed from a wheelchair.
- **C-shape pulls**, not knobs, on drawers and cabinet doors, which are easy to grasp and pull.



- **Pulls for wall cabinets placed as low as possible.** Lowering the cabinet may also be a good idea so that the bottom shelf can be reached from a wheelchair. You can also put in shelving to fill the space between the counter and the bottom of the wall cabinet.



- **Rounded or bull-nose edging along the counters and appliances** so your child does not hurt himself if he has a spasm, falls, or accidentally rolls into the counter.



- **Accessible sinks and faucets**, preferably with anti-scald devices. (As mentioned in the Bathroom section on page 53, an accessible sink allows a wheelchair to fit under it. Faucets should have lever handles or sensors and long spouts over the sink.)
- **Refrigerators with outside water and ice dispensers** so the child does not have to open the door and reach into the refrigerator for water and ice cubes.
- **Easy-open pantries** with frequently used items stored on the most accessible shelves.



- **Refrigerators with special storage compartments that are accessible from the outside.** Juice, soda, snacks, and other frequently needed foods can be stored in these compartments and easily reached without having to open the refrigerator door.

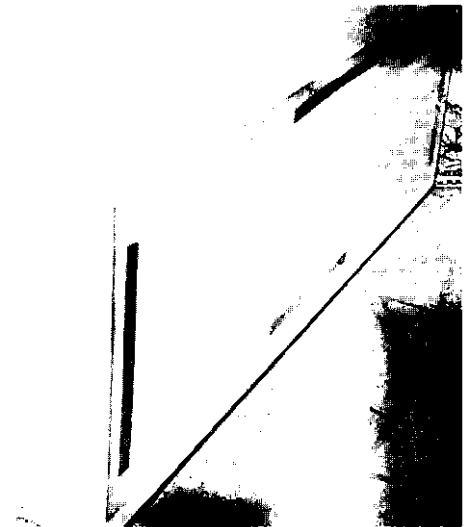

- **A refrigerator guard** to prevent the wheelchair from scratching the refrigerator door.

## Cooking Devices

Here are some tips on cooking appliances:

- **Place toaster ovens and microwaves at wheelchair height** (on lowered counters).



- **Make cooktops wheelchair-accessible.** Again the standard is 30 inches from the floor. They should be "drive under." with no cabinets underneath, so a wheelchair can fit under the cooktop.

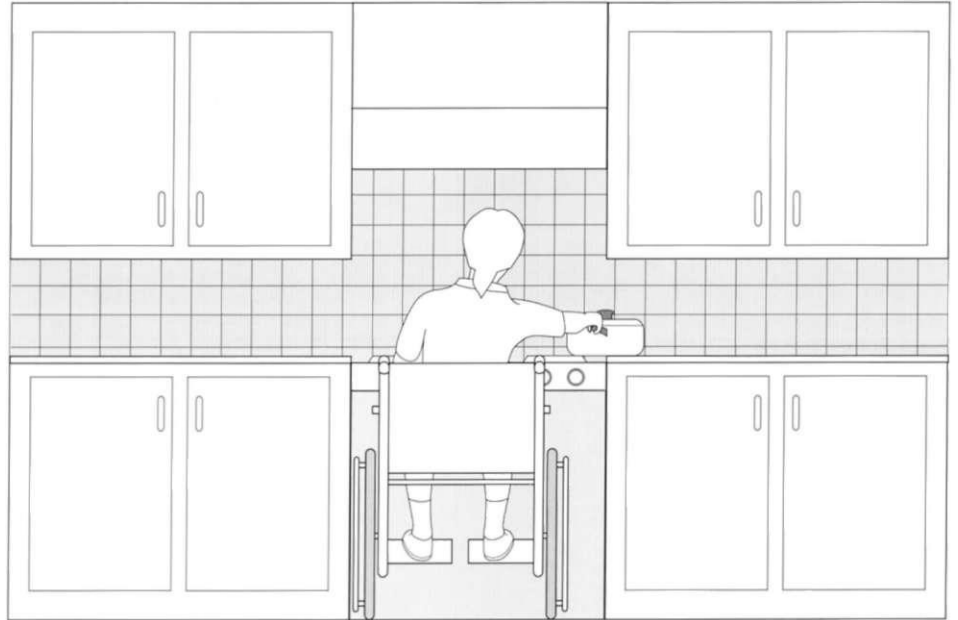

- **Place oven and burner controls in the front of the appliance** where they can be reached from a wheelchair. (Controls along a back panel are too far away and it could be dangerous to reach over a hot burner, pot or pan to get to them. Equally if the controls are placed on the side of the cooktop it may be difficult to reach the ones farthest from the front.)
- The controls should be spaced sufficiently far apart so someone with poor grasping ability, spasms, or uncertain hand control will be able to grip the desired knob more easily.

- **Install heat-resistant counter space** on either side of the cooktop. This provides a resting place for hot pots and pans after they have been removed from the burners. The counters should be level with the cooktop so an older child can just slide the pot or pan over onto the counter without having to lift it.



- **The oven should be wall-mounted with a side-hinged door at wheelchair height.** Ideally, there should be a heat-resistant shelf just below the oven door for placing hot cooking vessels on when they are removed from the oven.

The pan or casserole can then be transferred to a wheelchair-height heatproof countertop that is right beside the oven.

### Other Kitchen Recommendations

As well as taking up space, larger mobility devices mean more wear and tear on your kitchen floors. Heavier equipment can beat up a floor fairly easily. Smooth ceramic tiles with flush grouting, wood flooring, or other heavy-duty floor coverings will protect the surface for a longer period of time than sheet vinyl, vinyl composition tiles, and other softer flooring materials.

An adjustable-height table may also be a good idea. No matter what type of wheelchair or mobility device your child uses, it will always fit under the table if you can raise and lower the tabletop. Several families in our study purchased adjustable, pedestal-base kitchen tables which they felt worked out quite well.



*Oven at wheelchair height, but bottom-hinged door blocks access.*



*A combination with low oven and a microwave above and controls in between makes an accessible cooking unit.*

### Laundry Rooms

A conveniently placed, accessible laundry room is also an asset. With accessible appliances, such as front-loading washers, and dryers with side-opening doors, parents can teach more independent children how to do their own laundry. Ideally, the room should be in an easily reached, but somewhat private area. An older child may want to wash his dirty laundry in private. Laundry detergent and other cleaning agents should be easily reachable—but be careful if there are younger children in the house.

## Accessibility Around Your Property

We have presented tactics for creating accessible driveways and entries, halls and doorways, bathrooms, kitchens, and laundry rooms. One more area needs to be discussed that is frequently overlooked—your front and back yards. Your child needs access to the outdoors and the fresh air, and the opportunities for play and socializing that come with nice weather. You can provide safe outdoor access for your child through wheelchair-accessible decks and patios, screened porches, walkways, and swimming pools.

**Decks and patios** offer an enjoyable way to get your child outdoors. They also provide safe places where the entire family can be together. However, if you build a deck or patio, build an accessible one. For visual appeal, some decks have landings and then several steps down to the main deck. This may work well when your child is small and easy to carry down those few steps. But before you know it, your child will be too heavy to carry or will be using heavy mobility devices. So build your deck on one level. And be sure to add a ramp that leads down to an accessible walkway so your child has another way of getting out of the house.



*The entire family can enjoy the view from their spacious, accessible patio.*



*Wide sliding door opens onto large wooden deck.*



**Screened porches** may actually be preferable to decks for children who have compromised upper-body strength and control. Children who do not have the use or control of their arms cannot defend themselves against bees, wasps, mosquitoes, and flies. Nor can they apply sunscreen independently. A screened porch provides protection from insects and the sun and rain. The ideal home would have a screened porch with an adjacent deck or patio.

If possible, install **smooth, level pathways** around the property that are wide enough to turn a wheelchair around a corner or bend. This will allow your child to move around your property.

*“We installed wide concrete walkways around our house so my daughter could sit with me in her wheelchair when I garden.”*



*Accessible walkway extends around the exterior of the house.*



*Swimming pool with adjacent whirlpool (above). Pools provide physical and social opportunities for everyone in the family.*



*Pool lift swivels to lower child into water.*

*“The pool helped him socially because we could have pool parties.”*

#### Swimming Pools

Pools are good sources of exercise and recreation. They can also help to soothe muscles, especially if there is a whirlpool section. A pool has the added value of bringing other children to your home. Many of your child's friends will not have accessible homes and your house will have to be the center of his social life. A pool increases your child's opportunities to socialize.

If you have the space and the financial resources to build a pool, don't forget that your child may need special help getting in and out of it. Fortunately, several companies make swimming pool lifts, which are generally operated by water pressure. Portable steps are also available that make it easier to get into the pool. There are also ramps on the market but check them out carefully as some are too steep.

## General Accessibility Guiding Principles

We have stressed the unique challenges that each family faces in trying to create an accessible home. Since each situation is different, we cannot cover every possibility. However, here are some general guidelines for making every home friendly and accessible:

1. Avoid changes in levels.
2. Be cautious with floor coverings and the transitions between different types of flooring.
3. Create an unobstructed path through the house so your child can move freely from room to room (and exercise in the process).
4. Have everything placed at wheelchair level.
5. Provide electronic assistance to help your child turn electrical equipment on and off.
6. Arrange your furniture so there is room for your child in a wheelchair to participate in all family activities.
7. Place lighting fixtures properly so a child in a wheelchair can position himself in a good light for reading, doing homework, and so on.

## Chapter 5

# The Ideal Home...in the Right Neighborhood

Moving, remodeling. Few people like to think about it. Even fewer like to do it. But the fact is that families with a child with a disability *do* move. In fact, of the 65 families in our study, one-third had moved at least once in the past five years and more than half had moved in the past ten. Families move for a variety of reasons: a new job; a change in the household composition (increased or decreased family size, a divorce or remarriage); a shift in family finances; the desire for a better school system; or the need for a more accessible and supportive home.

At some point you and your family may find that it is just not possible or practical to remain in your present home. Or you may decide that it needs a major renovation. While moving and renovating can be exhausting and stressful, they also present an opportunity to live in a home that works better for you and your family.

One of the strongest findings of our study was that the environment of the home can make it harder or easier to raise a child with a physical disability. If you have the opportunity to create a more supportive home, you should seize it. The families in our study who did move almost all felt happy that they had because the long-term benefits far outweighed the short-term inconveniences. If you are able to choose the location, try to move so your child will be in the same school or school district and can remain close to his friends—assuming that you are satisfied with the school system.

### What to Look for

Whether you are planning to renovate, to move to a different house, or to build your own new home, ask yourself and your family: What should we look for?

Because we believe that a carefully designed home can improve the quality of life for everyone, we think about this question a lot, and we looked to the participants in our study for some answers. In our interviews we rephrased the question by asking both parents and children to describe an ideal home for a family where a child had a physical disability similar to theirs. Their responses were quite informative. First, because their spontaneous design recommendations helped to identify features of the home that were most important to them. Second, because their suggestions provided a capsule summary of the physical environment segment of our study.

The 65 parents in our study made a total of 321 spontaneous comments when they described the features of their "ideal" home. These comments covered a wide spectrum of issues—the interior and exterior of the home, the property, the neighborhood, and the surrounding community—and 88 percent of them related in some way to accessibility. When the children were asked the same questions, nearly 60 percent of their recommendations also related to improving access. These results reinforce our position that an accessible home is the gateway to safe and independent functioning for the child and reduced stress and strain for parents. That is why we have spent so much time talking about the importance of accessibility and describing ways to create it in and around your home.

We will mention the recommendations that repeat this information briefly here so you can use them as guidelines or a checklist of considerations if you are planning to move, to renovate, or to build. The "ideal" design features that are not discussed elsewhere in this book are described in somewhat more detail. Bear in mind that this is a partial listing of some of the things to consider when you are moving or modifying your home. There are many more possibilities. The ones that will apply most to you will depend upon your child's disability and your own particular situation.

## The "Ideal" House Design

Families identified a wide range of design features for their ideal home. Of course, many of the recommendations depend on the family having the financial resources to make them possible.

### House Form

The overall style or form of the house is very important. Parents felt that it should be:

- A one-level or a ranch-style home
- Subdividable into separate areas with distinct play/entertainment spaces. In the early years, young children can be casually but properly supervised while they play and older children can have privacy to be with their friends. Some parents suggested a self-contained apartment for young adults and/or an "au pair" suite for live-in help.



*Open floor plans make it easier to maneuver a wheelchair.*





*Wide hallway increases wheelchair access.*

## House Layout

The interior layout of the house can make life easier and more pleasant for the entire family. Since most of the children in our study used wheelchairs, their parents thought the layout should offer:

- A generous amount of space with large rooms that make it easy to navigate the wheelchair.
- An open/airy floor plan with spaces that flow into each other and help the child maneuver a wheelchair from room to room without making difficult turns.
- The "great room" concept. This is a combination kitchen/family room that increases family contact and the ability to monitor the child.
- Minimal distance between the areas that the child uses. The child's bedroom should be near the kitchen, the television/family/play room, and a fully accessible bathroom.

## Movement Through the House

The ability to move freely through the house in a wheelchair is a major priority. New and repeated suggestions from earlier chapters for enhancing movement in the ideal home include:

- Wide hallways
- Wide doors/doorways
- Easy-to-open doors—electronic/electric eye doors: doors with lever handles; bi-fold doors: accordion doors and sliding or pocket doors—if they are properly designed and installed
- Doorways without saddles or sills (and no door headers if a lift with ceiling-mounted tracks is needed)
- Bumpers for door frames so the wheelchair does not scratch the frame
- Level floors that are easy to roll over in a wheelchair—wood: tight-weave carpeting; vinyl sheathing; no grooves; no area rugs
- Tough, durable surfaces that will not get destroyed by a power chair—wood; ceramic tile

## Specific Rooms

Parents had a number of recommendations for specific rooms in the ideal home, such as the bathroom, the kitchen, and their child's bedroom. Suggestions for the bathroom and kitchen were already discussed in detail and are repeated here for convenience. Please see the Bathroom and Kitchen sections on pages 39-60 and 60-64 for more detailed information.

### Bathrooms

Overall, the bathroom should be large and accessible.

Specific recommendations for the **shower:**

- A 5-feet-by-5-feet roll-in shower.

- A hand-held shower head
- More than one shower in the house

### Considerations for a **bathtub:**

- A tub with a lift
- A raised or side-opening tub
- A hand-held shower head
- A whirlpool or "spa" tub

### Suggestions for the **toilet:**

- Wheelchair-accessible: raised seat, armrests, room for a rolling toilet chair, lift
- Grab bars
- Bidet
- Changing table that "grows" with the child

### Recommendations for the **bathroom sink:**

- Lower or adjustable height (depending on the height of your child and her mobility device)
- Lever or other accessible faucets with anti-scald control
- Space underneath for wheelchair (and plenty of counter space for toiletries)
- Pull-lever soap dispenser

### Kitchen

Some of the parents' spontaneous suggestions for the ideal kitchen:

- A large, open floor plan
- Accessibility features, such as:
  - Lower sinks, counters, and cabinets
  - Sink and counter cutouts or knee openings
  - Roll-out shelves/drawers
- Drawers and cabinets with accessible hardware pulls
- An ice/water dispenser in the refrigerator door
- A higher or adjustable table so the entire family can eat together

- Large, "Lazy Susan" table and corner storage
- Visibility to an adjacent play area so children can be watched from the kitchen

### The Child's Bedroom

Compared to their recommendations for the bathroom, the halls, doors, and other areas of the house, parents were not as specific about an ideal bedroom for their child. However, there are several things to consider in a child's bedroom:

- A first-floor location
- Accessible closets and other storage units, with the clothes rods low enough to be reached by someone in a wheelchair (no higher than 48 inches)
- Room by the bedside for transferring safely from a wheelchair
- An adjacent, accessible, and full bathroom that "flows" off the room for easy wheelchair entry—no hard corners to turn
- If indicated, a ceiling-mounted lift that carries the child from the bed to the shower and toilet. (These are generally recommended only for children with severe disabilities. You do not want your child to become more dependent on these lifts than is absolutely necessary since they are rarely found in the world outside the home.)

### Windows

Desirable design features even extended to the windows. Parents suggested that the windows in the ideal home be:

- Large—to let in natural light.
- Low—so a child in a wheelchair can see outside.
- Placed in the ceiling (skylights)—so a child who spends a lot of time in bed



*Outdoor space can be easily viewed from a wheelchair with these low windows. However, double-hung windows are difficult to open and close from a seated position.*

- can see the sky and the clouds.
- Accessible—so they can be opened and closed by someone in a wheelchair.
- Casement style—so a child in a wheelchair can easily reach and operate the opening and closing mechanism.

### Considerations for Special Rooms

Parents also had suggestions for special spaces. If you are thinking about moving, building, or renovating, consider having:

- **A big playroom.** This will give you the room you need to accommodate your child's equipment and play materials. Remember that your house will probably be the place where your child and his friends play. This room should be large enough to hold everybody.
- **A therapy room or space.** Some parents created therapy areas where their children could practice walking, crawling, standing, and have physical

therapy. Depending on your situation, you might need a large wall mirror, oversize floor mats, parallel bars for support while learning to walk, balance and practice stairs. Even children who do not walk may need therapy for moving limbs, flexing muscles, and other movement exercises.

- **A mud room with an accessible laundry area.** This room should be located between the house and garage. It provides a place for storing mobility equipment and cleaning dirt and mud off the wheels of a wheelchair before it enters the house. Ideally, a front loading washer and dryer should be here as well so your child's dirty or wet clothes can be removed and placed in the machines as soon as he enters the house. If your child is independent, he may want to take care of his own laundry in an area that is somewhat private.

- **A generous amount of storage space** for supplies and equipment— in the mud room, bathrooms, and bedrooms.
- **An extra bedroom** for guests and/or help.
- **Spaces that can be used in different ways as the child grows**—supervised play areas, private teen areas, or an independent apartment.

### Getting In and Out

This issue was covered extensively in Chapter 3. Parents felt that accessible entrances were vital features of their ideal home and their recommendations include:

- Ramps to the house or on-grade entries
- Power lifts
- Multiple wheelchair entrances
- An outside door to the bedroom of the child with the disability
- Fire exits

All these design features focus primarily on the interior of the house. However, the ideal home also has an attached garage, a nice piece of property, and is set in a supportive neighborhood and community—which we will discuss in a moment.

### Garage

Families felt that the garage in their ideal home should be:

- Attached to the house. (If the house does not have a garage, it should have a sheltered parking area.) This will allow your child to get in and out of the van away from the wind, the rain, and excessive heat and cold.
- A good size. There should be enough room for a conversion van with an extending lift. There should also be sufficient room to maneuver a wheel-

## Climate Control Systems and Electronic Equipment

We live in an age of sophisticated climate control systems and electronic devices. If you are moving or making changes in your home, you may want to consider the following heating, ventilation, and air conditioning (HVAC) systems and assistive technologies:

- **Central air conditioning.**
- **An airtight ventilation system to control dust. This is important if your child has respiratory problems.**
- **A standard coded electrical system with large spaces between the control buttons. This will allow a child with impaired hand function to grasp and regulate the controls.**
- **Accessible electronics equipment: CD players, radios, televisions, tape decks, all placed on low shelves.**
- **Environmental control units. These “smart house” features can automatically turn on the television, lights, answering machine, stove, microwave, and other appliances.**
- **Monitoring equipment. Intercoms and/or video monitoring devices will let you check on your child from other areas of the house.**
- **Electrical outlets and thermostats (for older children to regulate) placed in accessible locations and at accessible heights.**
- **Accessible lighting features. Options include lower, rocker switches; voice or touch sensor-activated lights; central boxes with remote control switches.**
- **Thermostat located at 48 inches so it can be read and operated by someone in a wheelchair.**

chair onto and off the lift. Many families also used the garage for storing equipment. If you plan to do this, provide plenty of space.

- Equipped with a ramp. The ramp should connect the garage interior with the interior of the house.

### The Grounds

Ideally, the outdoor space surrounding the house should provide:

- A flat, accessible yard, preferably large, with smooth walkways wide enough to turn a wheelchair around a bend
- Accessible play equipment

- A screened porch large enough for a wheelchair to maneuver in easily. The screens will protect the child from the sun and insects—especially important for a child with compromised upper-body control.
- A large, level deck or patio (in addition to the porch and adjacent to it), with a ramp to an accessible walkway or the driveway
- A swimming pool, possibly with a whirlpool, spa tub, and lift.
- A hot tub



*"I would like more of a neighborhood feeling—small town with a Main Street—a place where things are predictable. I didn't realize how much I would need to rely on the network of a neighborhood."*

## What Makes a Good Neighborhood?

Unless you live in a very rural area, your house is part of a neighborhood. This neighborhood, in turn, is part of a larger community. And your neighborhood and surrounding community will most likely have a big impact on you, your child with a disability, and the rest of your family. If your family is facing a move, don't just look at the house, condominium, or apartment. Look at the entire picture—the dwelling, the property it sits on, the immediate neighborhood, the town or community, and the people who live there. Unfortunately, it is difficult to know in advance exactly what your neighbors will be like. But there are some things you can do *before* you move to help you get a feel for the neighborhood:

- Try to spend time there—go in nice weather to see the number and ages of children playing outside.
- Talk to the parents, try to find out if other children with disabilities live in the community, and then talk to these parents about their experiences.
- Don't be afraid to ask questions. The type and quality of the neighborhood you choose will play a significant role in your and your child's life.

The best neighborhood will be one where you can stay and develop ties to your neighbors. As your children get older, it will be harder for you to uproot them and move. If you move in when your child is young, he will have the opportunity to develop long-term friends. The children will get to know one another at an early age. This makes it easier to forge strong friendship bonds.

*"This house is not very accessible to neighbors. There is a big distance between houses, our house is on a hill, and it is tough to go out and meet other kids."*

If you are considering a move, here are some general things to look for in a neighborhood:

### Social Characteristics

#### Other Children

Many of the families in our study felt that it was very important to live in a neighborhood with young families. They thought it was good to have children the same age as their child close by because:

- They can become playmates and helpmates. Your child can socialize and learn from the neighborhood children.
- Your child will grow up with the neighboring children if they are about the same age.
- Younger children can be more accepting of children with disabilities.
- Neighborhood children may introduce your child to their friends who live outside the neighborhood. This may expand your child's social world.

Several parents also thought it was nice if their child was not the only one in the neighborhood in a wheelchair.

## Adult Neighbors

Some characteristics of adult neighbors will be particularly helpful. Ideally, you want:

- Neighbors who are welcoming, caring, friendly—and who will look after your child occasionally if you cannot find a babysitter.
- Neighbors who live close by. You may form close friendships or bonds with them. They can help out in a pinch. Contact becomes easier when you see your neighbors informally over the course of the day.
- Neighbors who are not transient. You want to form long-term ties to your neighbors.

You should also look for a neighborhood that is very safe. If your child is independent, you will feel more comfortable letting him go out on his own. One or two parents felt an ideal situation is a small town where everyone will know (and look out for) your child.

*“An ideal neighborhood? It would have sidewalks, cul-de-sacs, low traffic, and families with lots of kids to come and play with or look after my child.”*

## What the Location Offers

Look for a house on a quiet street. If there is little or no through traffic, your child will be able to travel in her wheelchair without worrying about fast-moving cars and trucks. Try to find a property that has:

- Sidewalks with curb-cuts
- A cul-de-sac or dead-end street
- Alleyways that are safe to wheel along
- Only local traffic

Think about living close to a town center (or a mall or shopping center). You and your child will be able to go to stores and restaurants and see people without always having to get into a car or a van. If your child has the ability, being near a downtown will allow her to go shopping or browsing on her own. This will foster important feelings of independence. Neither of you will want to be stuck in the house all the time.

Look for a house near the school your child will attend. Not only will your child get to school more easily but your house could be a place where other children drop in and play with your child on their way home.

Look for a community that has activities and interesting things to do. Are there accessible parks? Is there a beach nearby with an accessible entrance? Is there a town recreational program, a YMCA, a YWCA, or a Jewish community center that has activities for your child? Are there sports programs and facilities? If appropriate, are there programs nearby geared toward children with disabilities such as Special Olympics and wheelchair sports?

Are the town's churches and temples accepting of children with disabilities? Are their facilities accessible?

*“Bumpy sidewalks are a problem but having my child grow up in the same neighborhood has been wonderful. An ideal neighborhood would have ranch houses, curb-cuts on sidewalks, and the ability to wheel everywhere.”*



*Hilly neighborhoods and two-story dwellings make it hard for a person in a wheelchair to visit neighbors.*



*Flat neighborhood with level lots and ranch-type homes is wheelchair friendly.*

Are there civic organizations that have programs for children with disabilities? In some towns the Elks, Lions, and Kiwanis clubs offer these types of programs.

Another question to think about is the location of the nearest good hospital. Can you reach it quickly if there is a family emergency? Several parents mentioned the importance of being near a first-rate medical center.

These are all things to consider, particularly as your child grows older.

### The Town's Physical Characteristics

An accessible community will make your life much easier and encourage your child to be independent as well. If you have options, look for an area that has:

- Paved streets that are easy to cross in a wheelchair
- Smooth sidewalks and curb-cuts all over town
- Flat terrain so it is easy to use a wheelchair
- Neighborhoods with a lot of ranch houses or houses with only a few steps up to the front door. This could make it possible for your child to visit friends in their houses, perhaps with the aid of a small portable ramp.
- Accessible shops and restaurants

### Schools

Getting the most out of your community schools is a topic for a separate book. We cannot possibly cover all the issues here. The first thing you should do if you are considering a new town or area is to talk to other parents about their experiences with the school system. Talk to the principal about the district's philosophy on educating students with special needs.

Here are some basic questions to ask potential neighbors and school officials:

- What is the school system's track record with children with disabilities?
- Are the schools physically accessible?
- How responsive are the schools to Individual Education Plans (IEPs)?
- What is the transportation system like? Are there vans and buses with lifts?
- Will your child be in the same school as the other children in the neighborhood?
- Are there after-school programs that your child can participate in, such as Scouts, sports, or community service?

### Ways To Avoid Potential Problems

**A number of families described their present or former communities rather negatively. Their advice for avoiding potential neighborhood problems:**

- **Try to find a neighborhood with plenty of children.**
- **Look for a neighborhood where the houses are fairly close to each other so you and your children will not feel isolated. Try to detect if there is real neighborhood feeling (do the families socialize, are there block parties, do the children in the neighborhood play with one another?). You don't want to live near children who are mean and unaccepting or parents who distance their children from yours.**
- **Make sure you will not have problems with vehicles stopping for the school bus when it picks up your child. (One family in our study had to go to court to resolve this situation.)**
- **Above all, talk to other families, especially those who have a child with a disability. They can offer a tremendous amount of guidance and support.**

Just as specific design features in the home make it easier or harder to raise a child with a physical disability, the neighborhood and the surrounding community can have a similar effect. We realize that when most families move, they don't have unlimited choices in the type of neighborhood they choose. Finances, the available housing stock, commuting time to jobs, the quality of the school system, are all factors that drive the choice of a neighborhood. However, all of our work with people with disabilities shows that if you have special needs, the area where you live will have a special impact on you and your family. Certain community and neighborhood characteristics will support your efforts to raise a child with a physical disability. Examine your needs carefully and then try to find a neighborhood that will meet them.

## Chapter 6

# Meeting Emotional and Social Needs

The goal of this manual is to help you create a supportive home environment for yourself and your child with a disability. As design researchers and architects, our primary focus is on the physical home—how you can make it safe, accessible, and responsive to the changing needs of your child as she grows and develops. However, we realize that a truly helpful home environment has to provide appropriate social and emotional supports as well. None of these supports—physical, social, or emotional—can exist in isolation. So while we spoke to parents and children primarily about physical and environmental needs, we also encouraged them to share their insights on their social and emotional needs. We wanted a comprehensive picture of the experience of raising a child with a disability. To get this, we explored the child's social and emotional life in three main areas—developing independence, making social contacts, and obtaining privacy—from both the parents' and the children's perspectives.

### Ways to Develop Independence

Feelings of independence are an important part of emotional well-being. Our work with adults with disabilities shows a direct link between the quality of their home environments and their feelings of independence and autonomy. We wanted to see how this relationship applied to children, so we asked parents to identify the tactics they used for increasing their children's strengths and independence.

We were deliberately questioning families whose children had a wide range of abilities, so some parents found this question irrelevant because their children were mostly or totally dependent on others for their care. For the majority of parents, however, independence was a very important topic. When they described their strategies for enhancing independence in their children, they provided a wealth of information. We hope these insights will be helpful to you.

Parents' tactics focused on the environment; special equipment and technologies; social, recreational, and educational strategies; physical care; and philosophical approaches to treating the child. We will discuss them in that order.

### The Physical Environment

Environmental features that increased independence mainly concerned accessibility and included design elements such as:

- "Everything accessible and at wheelchair level"
- One-level living so the child can go anywhere on his own
- Ramps and wide doors to encourage self-mobility
- Room size and furniture placement that allows wheelchair maneuvering without assistance
- Furniture arrangement that allows a child in a wheelchair to participate in all family activities
- An accessible bathroom so the child can bathe and toilet independently
- An accessible kitchen so the child can snack or prepare meals on his own
- Accessible light switches, fans, and windows so the child can control his environment

*"Adapt the environment to the child, not the child to the environment."*

*"(With the modifications) we do not need someone here at all times. He can be home alone now. He can come and go as he pleases. He's safe, and we don't worry if he's here by himself."*

- An accessible workstation where the child can do his homework independently
- Privacy for teenagers

All of these design features are discussed in detail in Chapters 3 and 4.

### Special Equipment and Technologies

There are an amazing number of gadgets and technologies on the market that assist independence. Among the devices that our families purchased and installed were:

- A remote-control unit for turning on various electrical items
- A trapeze and electric bed to increase upper-body strength and assist in independent transfers
- Remote controls for music and television
- Accessible controls for electronics equipment with large, color-coded, different-shaped controls that are easy to operate
- Computers for the child to use at an early age
- Telephones custom-designed for people with disabilities

*“My child can’t go out into the neighborhood like the other kids—but going swimming and horseback riding have been great for self-esteem. They make her feel social and independent, and having pets gives her a sense of responsibility.”*

### Activities

Parents thought that involving the child in as many activities as possible was a good tactic for encouraging self-esteem and feelings of independence. Some recommended activities:

#### Sports

- Swimming, track, tennis, bowling, basketball
- Bicycle riding on an adapted bike
- Horseback riding
- Challenger baseball, softball, Buddy-Ball
- Special Olympics or wheelchair sports

#### Other Activities

- Scouts
- Religious education (Confraternity of Christian Doctrine classes, Hebrew School, Sunday School, and other religious training)
- Pets (to create a sense of responsibility and break the ice socially)
- Volunteer and community service opportunities (These may ultimately lead to employment opportunities.)

*“Don’t let the child be isolated and don’t be over-protective.”*

#### Going Places, Doing Things

Parents thought it was important to get their children out of the house. They recommended doing as many things as possible with them: buy an accessible van and go places; tour state parks; go on outings; visit amusement parks (the newer ones are fairly accessible and have rides that can be accessed by children with disabilities); find playgrounds that have accessible equipment that can be used by all children.

*“We take our child everywhere. We don’t keep her isolated.”*

### Taking Advantage of Social Opportunities

Parents also felt that their children benefited from the opportunity to be with other children. This made them feel more normal and independent. Parents encouraged their children to be involved with peers; to play with children who have disabilities as well as children who do not; to hang out with their siblings and their friends; and to seek out cousins and other members of their extended families. Socializing is a very important topic and is discussed in greater detail on page 81.

### Treatment/Care

Parents thought speech, physical, and occupational therapies were all very good tools for improving strength and learning how to function as independently as possible. They also recommended arranging for ongoing therapy and developing a network of organizations and people to help with the child’s care and treatment.

### Disability Education

Education was an extremely important tool for achieving independence and benefited both the parents and the children. Parents noted that they themselves:

- Learned about their legal rights.
- Studied children’s developmental stages so they could offer appropriate guidance.

- Read catalogs and magazines and went to Abilities Expos and other trade shows to learn about products and assistive technologies that aid independence.

On behalf of their children, parents recommended:

- Mainstream\inclusive education whenever possible
- Full-day programs for younger or more disabled children
- A coordinated program, with teachers and physical, occupational, and speech therapists working together toward the same goals

#### Attitudes Toward the Child

Parents thought their attitudes and the way they treated their children were crucial for encouraging independence.

Their recommendations:

- Never be over-protective.
- Encourage the child to do things on her own.
- Set goals slightly above the child's level of functioning as an incentive.
- Encourage competitiveness through adapted sports programs and competitions.
- Have consistent expectations at home and at school.
- Ask the child questions, give choices, make the child feel involved and in control. (For example, at the most basic level, let her choose her own clothes.)
- Teach the child to stand up for her rights.
- Treat the child as normally as possible, don't favor her or restrain her unnecessarily.
- Include the child in all family activities, including cooking.

- Positively reinforce independent behavior and all attempts at it.

A wide range of strategies are listed here. Some may apply to your situation, others may not. We hope you can use at least some of them in your home.

*“Socialization is one of the biggest challenges. I always took my child everywhere. I never left her at home.”*

#### Meeting Social Needs

Developing a social life is a major step toward independence. Many families in our study struggled with their child's social needs. Some parents thought this was one of the most difficult aspects of raising a child with a disability. To understand the issues involved, we asked parents to comment on their children's social life throughout childhood. They described the problems they ran into and the strategies they used to try and solve them.

Tactics for fostering social contacts and for developing independence in children with disabilities often overlap. Many of the issues listed below will reinforce what was just discussed above. We are repeating them because we feel they are very important. Here are some typical social obstacles, followed by some suggestions for overcoming them.

*“Socialization becomes more difficult as the child gets older. It's hard to have friends when other people's houses are not accessible.”*

#### Potential Obstacles

##### The Environment

- Houses were not accessible enough, or large enough, for other children to come over and play.
- Friends' houses were not accessible. Their child could not get into potential playmates' homes.
- Sports facilities, such as a bowling alley or small area where children could do an activity, were not accessible.

##### The Child

- Was too passive to play or could not interact with other children.
- Had speech and communication problems.
- Had behavioral problems.
- Exhibited inconsistent and inappropriate social behavior.
- Worried about how he looked and was perceived. This was inhibiting.
- Was on a lower social level than other children his age. As he grew, the gap between him and his peers widened.
- Was not independent in toileting, or in self-catheterization, and this made socializing more difficult. (It is vital for children to learn to toilet independently as early as possible so that they will feel comfortable in social situations.)

##### Negative Attitudes of Other People

- Other children could be unfriendly and mean.
- Parents of other children did not know how to relate to a child with a disability.
- The parents tried to intervene with other neighborhood families but were not successful.



- As the child got older, other children became less accepting and stopped coming over.
- The school system was not supportive.

#### Other Stumbling Blocks

- Social contact was confined to family members.
- The child was not athletic in a community where this was very important.
- The child went to a special school and his classmates did not live nearby.
- Other children in the special school were more disabled. This made it harder to form friendships.
- The community only offered programs for children with intellectual disabilities. There were no role models for children with physical challenges.
- There were no programs for people over 18.
- The child was an only child. Built-in sibling companionship was lacking.
- The child's social life depended on the parents' ability to take him out. This was hard to do if the parents worked or were older and had to limit their driving.
- The family moved and the child was separated from long-time friends who were very accepting.

These are some of the difficulties that parents and children experienced in the social arena. While they can be significant, they are not insurmountable.

*“We have a ranch house. There is less isolation and more family interaction. The one level allows him to be where we are.”*

#### Coping Strategies

Here are some of the strategies that parents used to overcome these problems and create meaningful social lives for their children.

#### The Environment

- They created a "hub" on the main level of the home where the entire family could get together.
- They made their houses accessible. Parents built larger rooms to accommodate friends and other children with disabilities.
- They made their houses enticing (with swimming pools, hot tubs, toys, the latest electronic equipment) so other children would want to visit their child.
- They remained in the same neighborhood where everyone knew their child.
- They selected neighborhoods where there were a lot of children.

*“Wheelchair accessibility helped. Kids can come over and the entire class can come and swim in the pool.”*

#### Personal Strategies

- Parents took the initiative. They formed play groups; hosted play dates; had parties and sleep-overs; encouraged children to come over and let them try using the wheelchair and crutches; joined the PTA and other organizations so they could meet other parents.
- Families took their children out. They bought vans and went everywhere—the mall, camping, ballgames, boating, vacations, and so on. This stimulated their children and exposed them to other children.
- Parents hired aides, who were less protective than they, to do things with their child.
- Families found respite providers with older children who would play with their child.
- Parents developed close ties to friends who had children the same ages as theirs.
- Parents encouraged contact with cousins and other relatives.
- Siblings and their friends formed close ties to the child.
- The child learned to use a computer and socialize over the Internet. (This can be a mixed blessing. Instant "contact" over the Internet can lead to isolation of another type. These cyberspace friendships may rob children of the initiative to develop face-to-face relationships.)
- The family bought a dog and this attracted other children.
- Parents taught their children to speak up and not be shy.

*“A lot of parents are over-protective. You should mainstream children and keep them active—swimming, Scouts, sports, track, and so on. But we had to plan things and provide the transportation.”*

#### Participation in Formal Activities

- The children played regular or wheelchair sports (Challenger baseball, Buddy-Ball, Special Olympics).
- The children participated in special programs (Elks, March of Dimes, Arc).
- The children went to religious services and education classes regularly.
- The children went to camp.
- Families participated in respite programs.
- The child took music classes, played in a band, volunteered, or performed community services.

#### Experiences That Lead to Socializing

- Early intervention programs
- Patterning programs
- Full-time pre-school
- Head Start
- Day programs
- Therapy sessions with other children
- Depending on the child's abilities, being mainstreamed as much as possible or sent to a special school that provides a new social arena. Joining in school and after-school activities, including riding the school bus
- School trips

Developing a meaningful social network may be a major challenge for you and your child, depending on where you live, your school system, your child's personality, and her level of abilities. Parents developed a wide range of strategies to help their children connect with their peers. We hope some of these tactics will work for you as well.

#### Providing Privacy

For younger children, privacy is generally not an issue. Very few parents of small children mentioned problems with privacy. This changed considerably when the children reached school age and even more when they became adolescents. Privacy has many faces. There is physical privacy (to be alone or out of view of unwanted others), emotional privacy (to have private thoughts and feelings), social privacy (to be alone with a friend), and privacy of information—to mention just a few. We concentrated on physical and social privacy because they can be controlled to a greater degree by the physical environment.

Privacy issues focused on:

- Toileting
- Bathing
- Social privacy—having one's own room or space; being with friends away from the scrutiny of family

#### Toileting

This can be a particularly sensitive issue. As the child grows, he naturally will want more privacy for toileting needs. Parents discussed problems with toileting inside and outside the home.

#### Inside the Home

Here parents mentioned difficulties with:

- Children not wanting other people helping them in the bathroom or changing their diapers.
- Children not being able to close the bathroom door when they were on the toilet or in the tub.
- Embarrassment over using a urinal or a commode if they could not get to the bathroom or if the bathroom was not accessible.
- Problems with changing older children. A private place is needed to do this in the home.
- The need for a changing table that will "grow" as the child does.

Many of these issues could be solved by having an accessible bathroom that was easy to get to and use. For ideas, please refer to Chapter 4 on accessibility in the home.

#### Outside the Home

Here parents had problems with:

- Inaccessible public restrooms.
- Restrooms that were not unisex when the parent and child were of different genders.
- Changing tables in public restrooms that were too small for the child to use.

## Bathing

This was another issue that often became more difficult as the child grew. Many children no longer wanted to be helped with their baths or showers. An accessible tub or shower will solve this problem for more independent children. For children who cannot bathe or shower by themselves, assistance from same-sex parents, siblings, or aides can reduce some of the emotional discomfort of being washed by others. (And, of course, an accessible shower or tub will help everyone in the family.)

*“We are now adding a wing for our daughter on the main floor to give her more privacy and independence.”*

## Social Privacy

This becomes a fresh concern for all children as they grow older. Parents described various problems they and their children encountered with social privacy:

- The child shared a bedroom with a sibling. This was particularly difficult if the child with the disability did not sleep through the night or required some form of night-time care.
  - The child did not feel he had any private space of his own.
  - There was no place to be alone with friends.
  - Parents did not feel comfortable leaving the child home alone and the child felt he was constantly being monitored.
- Modified their house so their child could be left home alone safely to do what he wanted.  
Depending on your child's age and capabilities, privacy may not yet be a concern. As we tried to illustrate here, this will change as your child grows. It may be beneficial to think about your child's future privacy needs *now*—and start to plan how to meet them. We hope these examples of problems and solutions will help you with this planning.

Parents solved these issues through home design or modifications. For example, they:

- Gave the child with the disability his own room.
- Built a bedroom-and-bath suite, away from the parents' bedrooms, so the child could have his own space and time to himself.
- Created adjacent living-family rooms that were connected by French doors. The parents could be in the living room while the child and his friends were in the family room. Parents were nearby but out of sight.

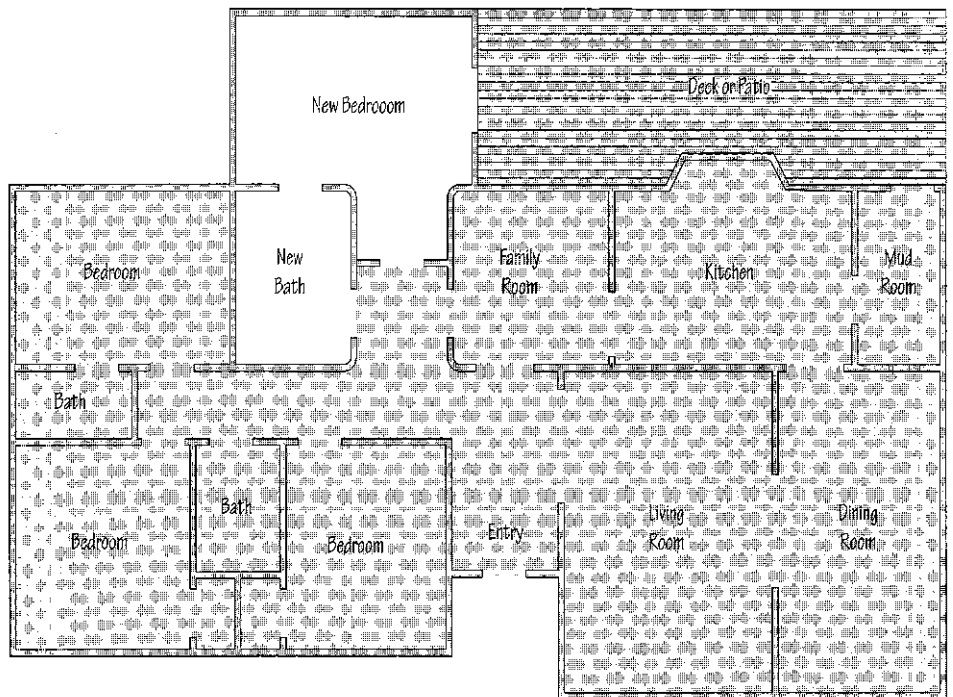

*Bedroom-bath addition combines privacy with easy access to the rest of the house.*

# Chapter 7

## Parent to Parent: Advice from the "Experts"

We began the research for this book with the assumption that parents of children with disabilities possessed a significant amount of knowledge that would be helpful to families confronting similar situations. Our interviews with the 65 parents and 12 children in the study confirmed this assumption. Many families possessed critical insight and hindsight that allowed them to evaluate their experiences, successes, and mistakes in a way that can be very beneficial to other families.

We tapped into our families' hindsight in two ways. First, we asked parents to review their experiences and tell us if there was anything that they would do differently if they had to do it over again. Second, we asked them if they had any advice to give to other parents facing a similar situation. Since we wanted to see how needs and situations changed over time, we asked parents to do this for each of their children's four major developmental stages:

- infancy-toddlerhood (birth to age 2)
- pre-school (ages 2 to 4)
- school-age (ages 5 to 11)
- adolescence to early adulthood (ages 12 and older)

Parents' recommendations and advice covered several major topic areas. These included:

- The physical environment of the home
- The location of the home
- Treatment/care of their child
- How to relate to the child with the disability
- Obtaining information
- Equipment/assistive technology
- School-related advice or strategies

Most of these issues have been covered earlier in this manual. We mention them

again here because they came to us in the form of advice and we feel they are important enough to be repeated.

In looking back over their experiences so far, most parents said that they would be more assertive or pro-active if they had to relive the past. This general philosophy applied to virtually all the advice categories.

### The Home Environment

When it came to their home environments, more than half of the parents in our group wished that they had handled their situation differently. These regrets fell into three related areas:

1. When they looked back, many parents wished that they had moved to a ranch or a one-level house. Or, if they had moved to this type of house, they wished that they had done so sooner. A number of them felt life would have been easier if they had made this move when their child was quite young. Parents specifically regretted buying raised ranches and split-levels (because of all the stairs) and old houses that needed a lot of work, which they did not have time to do.

2. Of the parents who did not want or were not able to move, some wished that they had arranged their homes so their child could live on the first floor. This meant creating a suite for their child with a bedroom and adjacent full-size accessible bath. If they were garden-apartment dwellers, parents wished that they had a first-floor apartment.

3. In retrospect, parents also wished that they had modified their houses to make them more wheelchair-accessible, or if they had modified them, that they had done so sooner.

*“I would have made changes earlier to the house to enhance independence—like getting in and getting out.”*

In terms of accessibility, the parents strongly advised other families to:

- Try to foresee accessibility needs. This will make it easier for you and your child.
- Make your house accessible sooner rather than later.
- Keep trying to make your house accessible. Sometimes it is an ongoing process.

## Location

Parents also evaluated *where* they lived and offered advice to other families who may be moving to a different community. They suggested a community that has:

- A neighborhood feel—a small town with a Main Street and a sense of predictability
- Opportunities for children—a YMCA, playground with accessible equipment, clubs, employment possibilities
- A neighborhood of ranch homes—if your child uses a wheelchair, he can visit other children nearby
- A lot of children
- Opportunities to form close ties to neighbors (for support, friendship, other children to play with, carpooling, babysitting)

- A warm climate (so you do not have to battle snow and ice with a child in a wheelchair). If moving is not an option, create a protected accessible entrance to the house that can be used in bad weather.
- A good hospital nearby
- Good state services and information for children with disabilities

*“Physical therapy helped a lot. It increased my child’s strength and enabled him to be independent in wheelchair transfers and other things.”*

## Getting Treatment, Care, and Help for Your Child

When parents looked back on their own experiences, or thought about advice to give to younger parents, they often made suggestions for obtaining the best treatment or help for their children. This advice applied to all stages of the child’s development. Parents recommended:

- **Self-education.** Talk to other parents, read up, be an “informed consumer,” know your rights.
- **Competent medical care.** Find doctors who know the disability; get disability specialists to perform surgeries; go where the good doctors are; get the best, not just who insurance companies say to use; find doctors you like and who make you comfortable; get multiple opinions.
- **Early intervention.** Get all the physical, occupational, and speech therapy and other *early* intervention that you can.

- **Accelerated treatment.** Get diagnosis early; use specialized medications and instruments sooner; get your child walking at as young an age as possible; use special exercises, braces, etc.
- **Increased therapy as your child grows.** Have physical, occupational, speech, and communication therapies keep pace with your child’s needs.
- **Specialized therapies if indicated,** such as patterning therapy; seating evaluations (so the child’s posture stays aligned); therapeutic horseback riding; bicycling; seizure treatment.
- **Psychosocial interventions,** such as psychotherapy; group therapy; sibling education programs; peer support groups for children and families.
- **Assertiveness.** Listen to but question doctors; be verbal and demanding. Don’t settle for unsatisfactory treatments. If medications or equipment are not working, push for a change.
- **Get as much help as possible and get it as soon as you can—**respite, or “another pair of hands to help”; explore after-school programs; try nannies and au pairs.
- **Flexibility and creativity.** These are essential qualities to develop.

Parents also gave the following advice:

- Make sure you are registered with your state disability agency that provides services.
- Don’t be embarrassed to ask for financial aid.
- Make multiple copies of your child’s medical records and send one to each of his doctors.

*“Don’t pamper your child. Don’t condone the attitude that the world owes him a living.”*

*“Look at every opportunity to get involved and never say ‘never.’”*

## How You Relate to Or Treat Your Child

Getting the proper treatment and support for your child is one of your most important tasks as a parent of a child with a disability. But how you treat or relate to your child is equally critical. When parents thought about what they might have done differently, or when they offered advice to other families, they often commented on this issue. Their suggestions:

- Encourage your child to be as independent as possible (and as soon as possible).
- Push your child to be as normal as possible. Let him try everything (within reason); help him adjust to the real world, join clubs, and so on.
- Treat your child like anyone else—don’t make him feel overly disabled. He may just need care longer than other children.
- Don’t smother, coddle, or over-protect your child (having another child may help to prevent this).

- Encourage your child to be with other children whenever feasible. Don’t let him miss out on socializing. Siblings can provide a distinct social advantage.
- Don’t leave your child home just because it is easier for you. Take him out in the world, find out about accessibility and then plan trips and outings. (National Parks are often quite accessible.)
- Encourage your child to do things in the community.
- Keep pushing for social programs.
- Apply to the Make-A-Wish Foundation before your child turns 18. (See page 105 in the Resource Guide).
- Keep an extra set of schoolbooks at home so the child does not have to carry them home each day.
- Be involved and physically active with your child; play sports if possible.
- Be patient and flexible (this can be particularly hard).
- Handle behavioral problems (such as excessive crying) quickly, consistently, and with confidence.
- See your child as a child, not a medical case.
- Do all you can for your child, but don’t neglect your other children or your spouse.
- Understand that medical and educational issues can be overwhelming. Recognize that you cannot do it all, then learn to pick your battles.
- Realize that you are only human and that caregiving has its limits. Take time for yourself.

*“I was surprised by everything.”*

## Obtaining Information

A number of parents regretted that they were not better informed about their child’s disability and the options that were available to them. Some parents, offering advice to other families, also emphasized the importance of obtaining as much information as possible. This “need to know” cut across all developmental stages and all disabilities.

*“Don’t give up. You must be forceful and persistent. You have to know what you are entitled to.”*

Parents felt that families need information on a wide variety of issues or topics, such as:

- **General knowledge about the disability.** Read *Exceptional Parent* (the magazine for families with disabilities) and everything else you can; learn about the condition; be prepared for what is coming in the future; get involved with local independent living centers and disability associations (cerebral palsy, spina bifida, multiple sclerosis, muscular dystrophy, etc.) from the beginning.
- **Treatment.** Find out about prognosis, requirements (what you *must* do), options, costs.
- **Equipment and assistive technologies.** Go to Abilities Expos and discover what is available and which products would work best for your child.

- **Home modifications.** Talk to other families; consult with health care and building professionals; find out which interventions work best. (But please talk to an architect or rehabilitation engineer *before* you do anything, to make sure the planned modification will work!)
- **Legal issues.** Know your rights for education.
- **Financial entitlements.** See if you qualify for Supplemental Security Income (SSI) from the Social Security Administration, and other government or private financial assistance. (See pages 103-105 in the Resource Guide.)
- **Other parents' experiences.** Join support groups and group therapy; join "Parent to Parent"—a support organization for parents; get ideas for justification/request memos; learn about other families' experiences with specialized therapies, such as shunts and G tubes.
- **Support agencies.** Understand their policies and linkages to each other.

## Equipment and Assistive Technologies

In this area parents also had a wide range of advice and expressed some regrets. We found that equipment needs can change drastically over time and that parents gave more advice about equipment as the child grew older. So we present their recommendations for equipment for each of the four developmental stages. Of course, these are not

meant to be complete lists of possible equipment. We provide them only to call your attention to the wide range of needs that may surface with your child.

*"I should have bought a van with a lift, and a lift for bathing sooner than I did."*

When they looked back on the **infant-toddler years**, some parents wished that they had obtained more equipment or information about equipment.

For the **pre-school years**, some of the equipment that parents wished they had bought included:

- a computer
- a gait trainer
- "Tumble Forms"
- special chairs
- a bath lift
- other seating and bathing aids
- a jogging stroller

During the **school-age years**, parents talked about the need for:

- lifts for the bed and bathroom
- a van with a lift
- a bicycle (There are bicycles made for wheelchair users.)
- an elevator with a telephone inside for emergencies
- electronic equipment (television, microwave, etc.) with bigger controls that are color coded and spaced so they can be grasped more easily by someone with limited hand control
- a float for the pool (These can be purchased, although one inventive father made a float with a boogie board and straps!)

Suggestions for the **teenage years** included items that would increase independence, including independence in ADLs:

- a computer
- front-loading washer and dryer
- pneumatic stander so the child could move from the bed to the chair by herself
- safe and accessible cooking equipment

## Advice About Schools

As we have noted, parents' experiences with schools, and their advice on getting the best education for a child with a disability, are topics for a separate book. This is a highly complex and emotionally charged issue. Policies vary widely by state, school district, and the abilities of the child. While we cannot hope to cover all the important points related to educating a child with a disability, the following advice from parents will provide you with some strategies for dealing with your school district or special school.

- Check out the schools system *before* you move.
- Make sure that all schools (including nursery school) are accessible.
- Be aware of your educational rights.
- Realize that you, as the parent, are in charge of the Individual Educational Plan (IEP).
- Prepare in advance for the IEP meetings. Be firm—you do not have to sign plans you do not like or agree with. Bring along a friend or advocate for support and advice.
- Don't be afraid to change schools (if you have that option) if the program is not working.

- Make sure that the school pushes your child intellectually. (Just because the child is in a wheelchair does not mean that she should not be challenged to excel academically.)
- Select a school where your child will be happy.
- Approach mainstreaming/inclusion with an open, yet critical, mind.

A few parents touched briefly on this last point of mainstreaming. This issue also deserves its own publication. While philosophically we are in favor of mainstream education, we realize that it may not work or be the best approach for all children. The extent of disability is the primary factor to be considered. Some parents did touch on the pros and cons of mainstreamed vs. special schooling. One parent felt that there were no role models in special schools; another mentioned that her son felt isolated in a regular school, although he did learn to live in the able-bodied world and find out "what the real world was like."

*“Advice? There are more options now, so take advantage of what is available now.”*

### **Why Listening to Other Parents Is Important**

The advice of more experienced parents can be particularly beneficial.

We live in a world where conventional attitudes toward disabilities are constantly changing. Growing advocacy movements, reinforced by the legal muscle of the Americans with Disabilities Act, place families with disabilities in a more forceful position. To put it simply, you and your child have more rights now than families had in the past. Other parents can help you to learn how to exercise these rights more effectively.

Advances in assistive technologies have also opened up fresh opportunities for children with disabilities that were not available just a few years ago. Several parents commented that there are now more options, services, and equipment

than in the past. Unfortunately, as the numbers of new technologies grow, it becomes increasingly difficult to keep track of them. Contact with other parents can help you keep pace with what is happening in the equipment and service marketplace.

Remember, other families have paved the way. You do not have to fight all of the same battles. You should have an easier time than parents and children did in the past. But your expectations should be higher. You should be as well informed as possible about all the design, service, educational, legal, and technological options that are available to you. Talking to other parents, advocacy organizations, and health care professionals will help you make the most appropriate choices in all of these areas.



## *Notes*

# Chapter 8

## The Children's Story

The major thrust of this book has been on parents' experiences with raising a child with a physical disability. However, we realize that the parents' story is by no means the only one. Their children's insights and recommendations are just as important. To give us the complete picture of living with a disability, we also explored the children's experiences. We were curious to know how they felt about many of the same issues that we discussed with their parents:

- Did things get easier or harder for them as they matured?
- What aspects of their homes helped or hindered them?
- How did they feel about their social lives?
- What would an ideal home and neighborhood be like, and were their ideas and recommendations different from those of their parents?
- What advice would they give to other children with disabilities and to parents raising a child with a disability?

Finally, while we deliberately did not investigate parents' experiences with school systems, we did ask the children about the situations in their schools.

We want to stress that the children's responses are not presented as the definitive, or final, word on children living with physical disabilities. Our information has several limitations. First, we only interviewed 12 children, and while they had a range of disabilities, they do not represent the spectrum of all children with physical disabilities. Second, because we wanted the children to look back and comment on their younger years, we spoke primarily to older children. Third,

the very fact that this information was obtained through interviews meant that we surveyed only children who had the communication and intellectual skills necessary to participate in an interview. Fourth, most of the children we spoke with had had developmental disabilities from birth. They were not traumatically disabled as a result of car accidents, head traumas, or spinal cord injuries. Their reactions could differ from those of children who became disabled later in childhood or adolescence.

Despite these limitations, the children's interviews were richly rewarding. We are ending this manual with the children's words and recommendations because we feel their experiences and advice provide a capsule summary of our entire study and are insightful and inspiring as well.

While we interviewed only a small number of children, we made the group as demographically diverse as possible:

- The children ranged in age from 9 to 20 years, with an average age of 15.
- Eight were male and four were female.
- Six lived in one-level houses, four in two-story homes, one in a split-level, and one in a one-level apartment.
- Six lived in suburban neighborhoods, four in small towns, and two in rural areas.
- Four had muscular dystrophy, four had cerebral palsy, three had spina bifida, and one had thrombocytopenia absent radius (TAR) syndrome.
- Ten of the twelve used wheelchairs regularly.

Here are their stories and recommendations.

## Memories of Childhood and Changing Needs

### Toddler to Pre-School

The children who remembered their young childhood and pre-school years generally recalled being carried a lot by their parents. These memories closely matched the parents' recollections. Several children described these early years somewhat negatively. For example, one child mentioned that their apartment was far from the parking area and her mother had to carry her a long way. Two spoke of the numerous surgeries they had in their early years. Others recalled stairs they couldn't climb on their own and wheelchairs they couldn't use indoors because their homes were too small.

However, the children for the most part did not feel that the house presented much difficulty at this stage of their life. This is consistent with their parents' feelings about the toddler and pre-school years. Things that the children enjoyed doing were no different from the things most young children like: playing with toys, "power wheels" with hand controls, and sandbox activities.

Half the children said they remembered making friends during this period. And like most children, they met their friends in the neighborhood, in pre-school, and at church or temple. However, other children said they didn't have many friends during this time.

When they spoke about things that increased their independence during these years, they, like their parents, mentioned equipment: a walker, a wheelchair, grab rails, and a bath seat. Home modifications that the children remembered included ramps, swimming pools, and carpeting on the floors so they could crawl or scoot.

*"It's always hard to make friends because of my disability. I still don't have a lot of friends—it's never easy."*

### School-Age Years and Adolescence

Again like their parents, the children reported greater difficulties as they grew and started school. More children described their school-age years negatively than positively. These were the years when it became obvious that their homes, without modifications, were inaccessible and unacceptable. Problems with stairs and second-floor bathrooms were mentioned. Most of the children who did not already have wheelchairs started using them during this period. Half of the children moved from apartments or two-story or split-level houses to one-level homes during this stage. The houses of the other half underwent major modifications. Parents built accessible bathrooms and/or installed such features as hydraulic bath lifts and other lifts throughout the house, a jacuzzi, stair glides, or an elevator.

When asked about anything that increased their independence during this

stage, children mentioned the same equipment and modifications that have already been discussed—mobility devices such as electric wheelchairs and three-wheeled vehicles; bigger rooms and accessible bathrooms; ramps and grab rails; accessible outdoor walkways; wide halls and doors; lowered light switches and lever door handles. Some children noted that getting a computer helped them significantly for both educational and recreational purposes.

One child went to a rehabilitation center where she reported:

*"They helped me figure out ways to do things on my own."*

Despite the many changes parents made to their homes at this time, inadequacies remained.

One child, whose accessible entrance was in the garage, complained:

*"It really bothered me that I couldn't go out the front door with everyone else."*

Another remembered:

*"I couldn't fit my walker in the bathroom, which meant I always needed help."*

A third child, who moved to a ranch house, recalled:

*"When I first saw this house, it looked huge without all the furniture. But now that we've taken up all this space with all our furniture and stuff, I feel closed in. I always need to crawl around and navigate my wheelchair around too much furniture."*

When asked if there was any equipment they would have liked to have (or have had) that they didn't, the children's responses were straightforward. They were not the least bit frivolous, as one might expect from children this age. Equipment requests focused on shower chairs, a commode, dressing and grooming aids, a wheelchair or scooter on every floor of a four-story house, and a voice-activated computer.

*"I wanted to go on a church group overnight, but the place they were going wasn't accessible."*

*"As you get higher in school, kids are less accepting and this was really frustrating."*

## Social Life

During these school-age and adolescent years the children's social lives became increasingly important to them. Several children remarked that making friends got easier as they became involved in school, temple, or church, and other group activities. They particularly enjoyed sports, such as horseback riding, swimming, karate, Buddy-Ball sports leagues, bowling, wheelchair racing, javelin throwing, and "hanging out."

Most had a decidedly "can-do" attitude, as a 10<sup>th</sup> grader explained:

*"There was nothing I didn't attempt—I've always kept the mind set that I'll try it."*

Unfortunately, socializing was not without pitfalls. Some of these obstacles were environmental, others were social and attitudinal.

One 11-year-old reported:

*"[Because of inaccessibility] I was never able to go over to other kids' houses to play — they always had to come to my house."*

At this stage of their lives several of the children described difficult social and emotional issues surrounding their disability. One was abused by other children in the neighborhood. Another recalled:

*"It was difficult. I had a lot of questions about why I was disabled. I felt depressed a lot about what I couldn't do."*

The teenagers in the study went on to discuss their high school years. Some described problems with classmates, while others found the kids at larger, regional high schools to be more accepting.

A 15-year-old had struggled with peer acceptance when he was 12 and 13, but said:

*"I have plenty of friends now."*

Unfortunately, this was not true across the board. One teen remarked that while he had friends at school, they never called him at home or got together with him apart from school.

Others described the difficulties in their social lives:

*"I didn't relate to people in high school—it was a challenge."*

However, the three people who now attend college all said their social lives had improved:

*"For the first time in my life, I have great friends who are my own age."*

## The Children's Ideal Home

The children, like their parents, were asked to imagine and describe an ideal house—what they would have if they could have anything they wanted. Although many responses involved accessibility, others involving technology were, in certain cases, somewhat whimsical. Their accessibility recommendations reinforce all of the features that we have stressed in this manual:

### General Accessibility

- "Everything accessible"
- One-level or an elevator and ramps
- Large rooms

### Specific Accessible Features

- **Doors**—automatic with sensors, wide, bi-fold, and pocket doors with some standard doors
- **Bathroom**—a tub with a whirlpool, a big bathroom, walk-in showers, a grab bar in the shower, a big commode, a low or special sink
- **Kitchen**—accessible kitchen, counters at the right level

- **Interior layout**—wide hallways, a basement game room, walk-out basement, a ramp to the basement from the outside, elevators, big bedrooms, a master bedroom and bath upstairs

*“Ideally, I’d like a robot who could do all the things my mom does for me”*

#### Technology and Other Amenities

- Computer access everywhere
- Voice-activated lights
- Accessible water fountains

#### Outdoor Spaces

- A front porch, patio, and/or deck
- A big yard for parties (and a dog!)
- A level yard
- A hot tub, trees and shrubs, accessible sidewalks, and a picnic table
- A swimming pool (recommended by half of the children!)

### The Children's Ideal Neighborhood

Like their suggestions for the ideal home, the children's descriptions of the ideal neighborhood were quite similar to their parents' recommendations. When asked to discuss their neighborhood and whether or not it was a good place for a kid with a disability, children named eleven features that they thought were

good and six that made it harder for them. A good neighborhood offered a suburban or small-town location, level terrain, a low-traffic street with sidewalks and curb-cuts, greenery, a park with accessible paths, friendly neighbors and lots of kids, and outside activities.

Neighborhoods that were harder to live in had mean kids, no sidewalks—this meant traveling along the shoulder of a busy road in a wheelchair, which could be quite dangerous—no curb-cuts, a “middle of nowhere” location, hilly terrain, and inaccessible houses with steps.

*“If there had been more ramps and accessible bathrooms, I wouldn’t have even needed an aide.”*

### Reactions to the School Environment

The children were also asked about their schools and how accessible they were. One of the children currently attended a special school for children with physical disabilities, and two others had attended such a school in the past. These children enjoyed these non-mainstreamed environments and, predictably, rated them as very accessible.

One child who had attended a special school and was then mainstreamed compared the two:

*“I loved the special school—that school was fun. I could get everywhere on my own. In gym the teachers would make sure everyone got involved. They would lift me up to shoot baskets and let me swing on*

*ropes. Now [in mainstreamed classroom] in gym they don't even try to let me do anything. They just want me to sit there on the side and watch and then they give me an "A." I wish the teachers would try harder and give me a chance—especially in gym. And now I have an aide. I really need the aide sometimes, but not all the time and this aide is always there. I wish she'd go away sometimes. It would be better if kids could pick their own aides instead of the school district doing it.”*

Children rated their mainstreamed schools generally as “fairly high” on an accessibility scale. However, their descriptions somewhat belied these ratings. Children described “bumping” down the stairs in a wheelchair during fire drills; narrow hallways and doors; no power-opening doors; the lack of an adaptive gym or an accessible auditorium; wheeling long distances in crowded hallways in a sprawling school; small bathroom stalls; inaccessible sinks and water fountains; and second floors they couldn't get to.

One teenager summarized the poor level of accessibility in his school:

*“I couldn't even get a drink of water for myself—the aide had to get it for me.”*

Other children remembered:

*“The wheelchair lift was always broken, and the elevator also broke down a lot.”*

*“My parents had to force the school to comply with the law. Because of me they now have a ramp.”*

Overall, schools did not receive glowing grades on their accessibility report cards. The children evaluated them and found many deficiencies. (We should caution the reader that school accessibility will vary widely from state to state and region to region. All of these children were from New Jersey.)

## Comparing the Two Perspectives

When we compared the children's responses with those of their parents, there were no major discrepancies. Parents, of course, remembered the child's infancy and young childhood. The children's memories of these early years relied primarily on what they had been told, and were vague at best. And throughout the interviews, while some parents gave detailed descriptions of the problems the child faced, children tended to minimize these same problems. However, there was one thing they did not minimize: problems with peer relationships.

Parents sometimes noted their child's difficulty in making friends or visiting playmates who lived in inaccessible houses. The children, on the other hand, were more inclined to discuss their struggles with peers and their problems maintaining close friendships. This was particularly true for the teenage years. To a certain extent, this is something every child has to deal with on his or her own. However, parents need to be aware of the devastating effects that insensitive children and isolation at school can have on their children. They should be vigilant and

make whatever changes are possible to minimize the negative behaviors of other children.

*“Attempt everything. Don't let your disability hold you back. Go after your dreams—you can do things no one else can do.”*

## The Children's Advice

The most poignant part of the interviews came at the conclusion when the children were asked: 1) what advice they would give to other kids who were growing up with a physical disability; 2) what suggestions they had for parents who were raising a child with a disability.

The children's advice to other children reflected their unwavering determination and general optimism:

- *“Just be positive.”*
- *“Anything is possible if you put your mind to it.”*
- *“Get involved in school and anything you can.”*
- *“Be thankful for what you can do. If kids ignore you, ignore them. Don't let it upset you — they don't know what they're missing.”*
- *“Try to make friends with other kids.”*
- *“Try to be as independent as you can. Have as many friends as possible, including pen pals.”*

The children's advice to parents was somewhat more pragmatic. The subjects ranged from independence, the physical environment, equipment, and accessibility,

to maintaining a positive attitude despite the hardships that may lie ahead:

- *“Treat them like a normal kid and let them do normal things, like go out with friends. Some parents are too nervous and over-protective—they should loosen up. Never say, ‘You can't do that.’ Encourage them to try whatever they want to. Make the kid's life as normal as possible.”*
- *“Don't be scared your kid will get hurt. Let them try things— let the kids make decisions.”*
- *“Encourage kids to do exercise.”*
- *“Buy a wheelchair-accessible house.”*
- *“Make sure school trips are accessible.”*
- *“Get the equipment that you need— don't say, ‘Use this temporarily.’”*
- *“It's hard to watch your kids struggle, but try not to feel too bad about it. Know your kid's needs and work from there.”*
- *“Treat them just like other kids.”*
- *“Be happy that your kids are here.”*

*“Find out everything you can about your kid's disability. Expect that things will go wrong. Don't be in denial—it doesn't help your kid and it won't help you. Question everything. Encourage your kids to do normal things—they belong in mainstream society.”*

# Closing Comments

These were our initial goals for

*A House for All Children:*

- To sensitize families to the important role played by the physical environment of the home in raising a child with a physical disability.
- To illustrate how a family's needs will change over time as the child with the disability grows up and how the home environment must adapt accordingly.
- To provide guidelines for creating the proper level of physical, social and emotional supports in the home.

We hope that we have met these goals and that you have found information here that is helpful to you and your family. We now want to close this manual with a few final words about home design. Of course, making modifications to create a barrier-free home and buying specialized equipment and assistive technologies can be costly. But, if you have (or can obtain) the resources to modify your home, it is well worth the investment of time and money.

Your child will function better and the physical and emotional demands placed on you will be reduced.

We would be naive to assume that money is not an important issue in most households. But it is worth thinking about the cost of barrier-free design in terms of its broader benefits—or what is now known as universal design. The basic principle of universal design in housing is that many of the barrier-free features needed for children with disabilities also help the entire family. Such basics as no-step entrances make it easier to roll a baby stroller or tricycle into the house, as well as a wheelchair. Wider doorways allow a wheelchair to move around the house. They also make it easier to carry in packages and move furniture.

Lever handles are easier for someone in a wheelchair to use and are helpful for children and anyone with arthritis or a grip problem. Walk-in showers are safer for everyone in the family and will allow parents to "age in place" as they grow older. Adding a piece of furniture, like a chair or a bookcase, to the large bathroom necessary for a wheelchair can make it look quite elegant. Everyone finds rocker-style light switches and C-shape cabinet

and drawer pulls easy to use, especially if they are carrying or holding something, and higher electrical outlets are much easier to reach than low ones. The lower kitchen countertops with knee openings that let a child sit in a wheelchair and work at the counter are just as convenient for someone who likes to sit down while preparing vegetables.

These are just a few examples of universal design in action. So when you consider the costs of adaptive modifications, try to view these expenses more broadly. Many of these designs or adaptations will be helpful not just for your child with a disability but to everyone in your family—and especially to you as you get older.

In closing, we want to wish you well in raising a child with a disability. We hope that our work with other families, which led to this book, will help you in this challenging and rewarding task.

# Developmental Checklist

## A House For All Children

### Infancy

<b>Feeding</b>	Room at kitchen table for high chair or special feeding chair
<b>Diapering</b>	Changing table near crib, another in bathroom
<b>Bathing</b>	Large sink, special infant tub, inflatable bath seat
<b>Sleeping</b>	In parents' room or adjacent room with monitor so child can be heard
<b>Transporting child in and out of the house</b>	Stroller-carriage or special mobility equipment
<b>Infant stimulation</b>	Mirror, mobiles, and so on
<b>Driving</b>	May need extra supports in car seat

### Toddler

<b>Feeding</b>	Room at kitchen table for high chair or special feeding chair (as well as room for other family members). Kitchen large enough for mobility device
<b>Toileting/ Diapering</b>	Changing table near crib, another in bathroom, room for potty seat (if using)
<b>Bathing</b>	Large sink, larger tub, bath seat or chair. Room in bathroom for mobility device if now using one
<b>Sleeping</b>	May still need child close by. Adjacent room with monitoring capability or still in parents' room
<b>Mobility/Transporting</b>	Room for walker, stroller, small wheelchair to get up to and through outside doors
<b>If crawling</b>	Safe crawling area—carpeted, easy to monitor
<b>If mobile</b>	Control access: childproof outlets, cover sharp corners on cocktail tables and floor cabinets, block access to stairs, low cabinets, and objects on low tables. Safe outdoor play area
<b>Therapy area</b>	Room for floor mats, wall mirror, rails for learning balance, a stander and other pieces of equipment such as a playboard or scooter board

### Pre-School (2-4)

<b>Feeding</b>	Space at the table and in the kitchen for feeding chair and/or wheelchair (or other mobility device)
<b>Toileting</b>	Changing table (in bedroom and bath if still using diapers), room for potty seat (bedroom and bathroom), space adjacent to toilet for learning how to transfer
<b>Bathing</b>	Room for mobility device in the bathroom, room at the sink, ability to get into tub or shower, bath or shower chair, raised tub or other bathing assists
<b>Sleeping</b>	May still need to monitor—sleep in or close to parents' room with monitor
<b>Transporting</b>	If child is in wheelchair, may need a van
<b>Mobility</b>	May still need to prevent access to stairs, cabinets, electrical outlets, and so on Ability to move child and wheelchair through the house, through doors, into the bedroom, and into the bathroom Safe outdoor play area and the ability to reach it via deck and ramp Special play equipment such as a special swing Ability to get child (and equipment) up to and through the outside doors Ability to get larger child into and out of the family vehicle Grab bars and lower railings on stairs if child is learning to walk



<b>Play space</b>	Room for child and his/her friends, room for parents to sit and talk while observing children, safe outdoor play area
<b>Therapy room or area</b>	Stander, crawl space, gait training, and so on
<b>Seating</b>	Variety of options

### **School-Age (5-11)**

<b>Kitchen</b>	Room for wheelchair at the table and to maneuver around the kitchen, ability for child to get snacks and beverages
<b>Bathroom</b>	Accessible bathroom on main level. Room for wheelchair to turn around, wheelchair-accessible sink with mirror and counter space for grooming; accessible tub and room for lift (if needed), roll-in or transfer-in shower stall (large enough for shower seat), room at side of toilet for transfers (or large changing table if using diapers)
<b>Mobility</b>	<p>Accessible area for child to get in and out of the car</p> <p>Accessible area for getting on and off the school bus</p> <p>Accessible path to front and/or other exterior doors</p> <p>Ramp or on-grade entries (front door, side door, via garage, etc.)</p> <p>Accessible door entries with clear space next to door on landing for wheelchair</p> <p>Accessible halls and doorways inside the home</p> <p>Room for wheelchair to maneuver through and use all social areas (living room, dining room, family room, kitchen, etc.) so child can be active participant in all family activities</p> <p>Need accessible workspace for homework and computer</p>
<b>Bedroom</b>	Preferably on first floor. Accessible doorway, dresser, and closet. Room by bed for lift or wheelchair transfer. Accessible bathroom nearby or space for commode in bedroom. If in diapers, will need larger changing table
<b>Upper level</b>	Stair lift or elevator if unable to provide accessible bathroom/bedroom on main level
<b>Recreation</b>	Play space where child can be with friends and still be informally monitored by parents
<b>Outdoors</b>	<p>Ability to go outside onto accessible deck, patio, or screened porch</p> <p>Ability to move around the property and the neighborhood with wide, flat, and smooth pathways, sidewalks, and curb cuts</p>

### **Adolescence (12 years and older)**

#### **All of the School-Age Needs Plus:**

<b>Kitchen</b>	Ability to prepare food, do dishes, clean up (accessible sink, counters, appliances, etc.)
<b>Laundry</b>	Access to a laundry room where can do own laundry in private
<b>Recreation</b>	<p>Ability to be alone with friends</p> <p>Access to television, VCR, radio, and CD players and room for this media equipment in bedroom and family room</p> <p>More sophisticated computers for homework, communication</p>

# Resource Guide

The following is a partial list of disability resources that may be helpful to families. For a more comprehensive listing contact the following organizations or obtain a copy of the "2000 Resource Guide" published by *Exceptional Parent Magazine*. To purchase this guide, call toll-free 1-800-372-7368 or 1-800-535-1910.

## General Disability Resources

1. NICHCY (National Information Center for Children and Youth with Disabilities)  
P.O. Box 1492  
Washington, DC 20013-1492  
1-800-695-0285 (voice/TTY)  
1-202-884-8441 (fax)  
<http://www.nichcy.org/>  
[nichcy@aed.org](mailto:nichcy@aed.org)

NICHCY is the national information and referral center that provides information on disabilities and disability-related issues for families, educators, and other professionals. The organization's special focus is children and youth from birth to age 22.

2. The National Alliance of the Disabled, Inc. (NAOTD)  
1352 Sioux Street  
Orange Park, FL 32065  
<http://www.naotd.org/>

The mission of the NAOTD is to serve as a collective voice of persons with disabilities to assure that their rights to equal access, as promised and protected by the Constitution, are not diminished or denied. The focus and purpose of the NAOTD is to emphasize the abilities of persons with disabilities, the dignity of self-determination, and the economic and social rationale of inclusion.

3. TASH  
29 West Susquehanna Ave.,  
Suite 210  
Baltimore, MD 21204  
1-410-828-8274 (phone)  
1-410-828-6706 (fax)  
<http://www.tash.org>

TASH is an international association of people with disabilities, their family members, other advocates, and professionals fighting for inclusion of all people in all aspects of society. Its members are concerned with human dignity, civil rights, education, and independence for all individuals with disabilities. TASH's mission is to eliminate physical and social obstacles that prevent equity, diversity, and quality of life.

4. Office on Disability and Health  
Division of Child Development,  
Disability, and Health  
National Center for  
Environmental Health  
4770 Buford Highway (F-29)  
Atlanta, GA 30341  
1-770-488-7080 (phone)  
1-770-488-7075 (fax)  
<http://www.cdc.gov/nceh/programs/cddh/schome.htm>

The Office on Disability and Health is part of the Division on Child Development, Disability, and Health of the National Center for Environmental Health at the Centers for Disease Control and Prevention (CDC) in Atlanta. The Office supports several programs, projects, and activities aimed at maintaining and improving the health of families, adults, and children living with disabilities.

5. Children with Disabilities Web Site  
<http://www.childrenwithdisabilities.ncjrs.org/>

This Web site offers families, service providers, and other interested individuals information about advocacy, education, employment, health, housing, recreation, technical assistance, and transportation covering a broad array of developmental, physical, and emotional disabilities. Federal, state, and local resources are listed.

6. Enable, Inc.  
605 Neponset Street  
Canton, MA 02021  
1-781-828-4770 (phone)  
1-781-575-0078 (fax)  
<http://www.enable1.org/>  
[jl@enable1.net](mailto:jl@enable1.net)  
[mar@enable1.net](mailto:mar@enable1.net)

Enable's mission is to demonstrate leadership in the development, provision, and management of innovative social, vocational, and health services for children, adolescents, and young adults with disabilities, and their families.

**Note:** If your child has a developmental disability, the first place to contact for assistance may be your state office on developmental disabilities and mental retardation. The name of the agency, and where it is located in state government, may differ for each state. They are usually part of the State Department of Human Services. Check the state agency listings in your telephone book for contact information. Your state and county may also have a general Office on Disability that can help you with service needs.

# Resource Guide

## National Offices for Major Disability Groups

American Association on  
Mental Retardation  
444 North Capitol Street, NW,  
Suite 846  
Washington, DC 20001-1512  
1-202-387-1968 (phone);  
1-800-424-3688 (phone)  
1-202-387-2193 (fax)  
<http://www.aamr.org>

American Paralysis Association  
500 Morris Ave.  
Springfield, NJ 07081  
1-973-379-2690 (phone);  
1-800-225-0292 (phone)  
1-973-912-9433 (fax)  
<http://www.apacure.org>  
Paralysis@aol.com

The Arc of the United States  
National Association on Mental  
Retardation  
1010 Wayne Ave., Suite 650  
Silver Spring, MD 20910  
1-301-565-3842 (phone)  
1-301-565-5342 (fax)  
<http://www.thearc.org/>  
Info@thearc.org

Autism Society of America  
7910 Woodmont Ave., Suite 300  
Bethesda, MD 20814-3015  
1-301-657-0881 (phone);  
1-800-3AU-TISM, x150 (phone)  
1-301-657-0869 (fax)  
<http://www.autism-society.org/>

Brain Injury Association  
105 North Alfred Street  
Alexandria, VA 22314  
1-800-444-6443 (phone)  
1-703-236-6001 (fax)  
<http://www.biausa.org>

Children and Adults with Attention-  
Deficit/Hyperactivity Disorder  
(CHADD)  
8181 Professional Place, Suite 201  
Landover, MD 20785  
1-301-306-7070 (phone)  
1-301-306-7090 (fax)  
<http://www.chadd.org/>

Easter Seals  
230 West Monroe Street, Suite 1800  
Chicago, IL 60606  
1-312-726-6200 (voice)  
1-312-726-4258 (TTY)  
1-312-726-1494 (fax)  
<http://www.easter-seals.org/>  
info@easter-seals.org

Muscular Dystrophy Association  
U.S. National Headquarters  
3300 East Sunrise Drive  
Tucson, AZ 85718  
1-800-572-1717 (phone)  
<http://www.mdausa.org/>  
mda@mdausa.org

National Multiple Sclerosis Society  
733 Third Ave.  
New York, NY 10017  
1-800-344-4867 (phone)  
info@nmss.org

National Organization for Rare  
Disorders, Inc.  
P.O. Box 8923  
New Fairfield, CT 06812-8923  
1-203-746-6518 (phone);  
1-800-999-6673 (phone)  
1-203-746-6481 (fax)  
<http://www.rarediseases.org/>

National Spinal Cord Injury  
Association  
8701 Georgia Ave., Suite 500  
Silver Spring, MD 20910  
Helpline: 1-800-962-9629  
1-301-588-6959 (phone)  
1-301-588-9414 (fax)  
<http://www.spinalcord.org/>  
nscia2@aol.com

Spina Bifida Association of America  
4590 MacArthur Blvd., NW,  
Suite 250  
Washington, DC 20007-4226  
1-202-944-3285 (phone);  
1-800-621-3141 (phone)  
1-202-944-3295 (fax)  
<http://www.sbaa.org>  
sbaa@abaa.org

United Cerebral Palsy Association  
1660 L Street NW, Suite 700  
Washington, DC 20036  
1-800-872-5827 (phone)  
1-202-776-0414 (fax)  
<http://www.ucpa.org>

## Information and Advice on Home Modifications

1. Accessible and Usable Buildings and Facilities, ICC/A117.1-1998  
American National Standards Institute, Inc. (ANSI)

This publication provides standards for accessible design. It can be ordered through:

BOCA International, Inc.  
4051 West Flossmoor Road  
Country Club Hills, IL 60478-5795  
1-708-799-2300 x720 (phone)  
<http://www.bocai.org>

2. The Architectural and Transportation Barriers Compliance Board ("The Access Board")  
1331 F Street, NW, Suite 1000  
Washington, DC 20004-1111  
1-800-872-2253 (voice)  
1-800-993-2822 (TTY)  
1-202-272-5447 (fax)  
info@access-board.gov

The Access Board is an independent federal agency that ensures that certain facilities designed,

constructed, altered, or leased with federal funds since September 1969 comply with accessibility standards issued under the Architectural Barriers Act of 1968 (Public Law 90-480). The agency also sets the guidelines and provides technical assistance for the Americans with Disabilities Act (ADA) of 1990 (Public Law 101-336). The ADA is a civil rights law that ensures that persons with disabilities have access to public accommodations, including hotels, restaurants, theaters, retail stores, parks, zoos, transportation terminals, and other facilities open to the public. The Board produces or distributes a variety of publications, including design standards for architectural access in a variety of settings. In addition, the Access Board has responsibility under the Telecommunications Act of 1996 to develop accessibility guidelines for customer equipment and telecommunications equipment.

3. New Jersey Barrier-Free Sub-Code (New Jersey Administrative Code 5:23-7)

For technical assistance and information about these accessibility requirements, contact:

Division of Codes and Standards  
State of New Jersey  
Department of Community Affairs  
P.O. Box 802  
Trenton, NJ 08625  
1-609-984-7609 (phone)  
<http://www.state.nj.us/dca/programsbook/dcs.htm>

4. Center for Universal Design  
North Carolina State University  
School of Design  
Box 8613  
Raleigh, NC 27695-8613  
1-919-515-3082;  
1-800-647-6777 (voice)  
1-919-515-3082 (TTY)  
1-919-515-3023 (fax)  
<http://www.design.ncsu.edu/cud>  
[cahd@ncsu.edu](mailto:cahd@ncsu.edu)

The Center for Universal Design collects and distributes information on accessible housing; conducts research to test ideas and develops new information on accessible housing and universal products; provides training for designers and others in the building industry; offers technical assistance to families, companies, and agencies; and develops training for therapists, family members, and people with disabilities. The Center is building a nationwide Accessible Housing Design Advisory Network of individuals with disabilities, their families, and friends to allow the Center's designers and researchers to solicit opinions, review ideas, evaluate training programs, and test housing or product designs.

5. Center for Inclusive Design & Environmental Access (IDEA)  
School of Architecture and Planning  
SUNY— Buffalo  
Buffalo, NY 14214-3087  
1-716-829-3485 (phone)  
1-716-829-3861 (fax)  
<http://www.ap.buffalo.edu/~idea/>  
[idea@ap.buffalo.edu](mailto:idea@ap.buffalo.edu)

IDEA is dedicated to improving the design of environments and products by making them more usable, safer, and appealing to people with a wide range of abilities throughout their life spans. Originally based on the concepts of accessible or "barrier-free" design and normalization, the work has expanded to embrace the concept of universal design, or design of places and

products that work for a broad range of people, including people with disabilities. IDEA provides resources and technical expertise in architecture, product design, facilities management, and the social and behavioral sciences to further these agendas.

6. National Institute on Disability and Rehabilitation Research (NIDRR)  
U.S. Department of Education  
600 Independence Ave., SW,  
Room 360, MES  
Washington, DC 20202-2572  
1-202-205-8134;  
1-800-346-2742 (voice)  
1-202-205-9136 (TTY)  
1-202-205-8515 (fax)  
[james\\_doherty@ed.gov](mailto:james_doherty@ed.gov)

The Institute administers the principal federal disability research programs and Americans with Disabilities Act (ADA) technical assistance centers through ten regional Disability and Business Technical Assistance Centers (DBTACs). The DBTACs act as "one-stop" central sources of information, direct technical assistance, training, and referral on ADA issues, and provide individualized responses to information requests, referrals to local sources of expertise, and training on ADA provisions and disability awareness.

To reach the center closest to you, call 1-800-949-4ADA (voice and TTY).

7. Enable's Assistive Technology Program  
1603 Court Street  
Syracuse, NY 13208  
1-315-455-8591 (voice)  
1-315-455-1794 (TDD)

Enable's Assistive Technology department is authorized to provide services for families and individuals with developmental disabilities,

# Resource Guide

traumatic brain injuries, or other physical disabilities. An adaptive technician can evaluate, design and build adaptations for the home. Enable is a not-for-profit organization, but it does charge for services. Enable works with Medicaid, school districts, private insurance, and other funding sources.

8. National Resource Center on Supportive Housing and Home Modifications  
Andrus Gerontology Center  
University of Southern California  
3715 McClintock Ave.  
Los Angeles, CA 90089  
1-213-740-6060 (phone)  
1-213-740-8241 (fax)  
<http://www.homemods.org>

The Center focuses mainly on design for the aging but it also issues publications of general interest that focus on home modifications and accessible design.

## Information and Advice on Assistive Technology

1. The Technology-Related Assistance for Individuals with Disabilities Act of 1988 ("The Tech Act") provides funding to 50 states and six territories to promote consumer-responsive technology devices and services. Its purpose is to provide product and funding resource information, model demonstration, innovative projects, and consumer awareness training programs.

An assistive technology device is defined as "any item, piece of equipment, or product system, whether acquired commercially, modified or customized, that is used to increase, maintain, or improve the functional capabilities of individuals with disabilities."

RESNA Technical Assistance Project  
1700 North Moore Street, Suite 1540  
Arlington, VA 22209-1903  
1-703-524-6686 (voice)  
1-703-524-6639 (TTY)  
1-703-524-6630 (fax)  
<http://www.resna.org/taproject/at/statecontacts.html>

RESNA's (Rehabilitation Engineering and Assistive Technology Society of North America) purpose is to improve the potential of people with disabilities to achieve their goals through the use of technology. Each state has a Technology Assistive Resource Program (TARP) that provides information and referrals concerning assistive technology. RESNA's Web site provides an up-to-date list of state TARPs along with other assistive technology information.

2. ABLEDATA  
8455 Colesville Road, Suite 935  
Silver Spring, MD 20910  
1-301-608-8998;  
1-800-227-0216 (voice/TTY)  
1-301-608-8912 (TTY)  
1-301-608-8958 (fax)  
<http://www.abledata.com>  
[abledata@macrpoint.com](mailto:abledata@macrpoint.com)  
[kabelknap@aol.com](mailto:kabelknap@aol.com)

ABLEDATA is a federally funded project whose primary mission is to provide information on assistive technology and rehabilitation equipment available from domestic and international sources to consumers, organizations, professionals, and caregivers within the United States. The ABLEDATA database contains information on assistive technology products. The database gives detailed descriptions of each product including price and company information. It also contains information on noncommercial prototypes, customized and one-of-a-kind products, and do-it-yourself designs.

3. Trace Research & Development Center  
University of Wisconsin—Madison  
5901 Research Park Blvd.  
Madison, WI 53719-1252  
1-608-262-6966 (voice)  
1-608-263-5408 (TTY)  
1-608-262-8848 (fax)  
<http://trace.wisc.edu/web@trace.wisc.edu>

Trace is a research center at the University of Wisconsin—Madison that focuses on making off-the-shelf technologies and systems, such as computers and information kiosks, more accessible for everyone through the process known as universal, or accessible design. Trace is largely funded through the National Institute on Disability and Rehabilitation Research (NIDRR). Trace is designated as the Rehabilitation Engineering Research Center (RERC) on Information Technology Access, one of 15 such centers scattered throughout the country, each with a different Rehab. Engineering orientation. Trace's specific focus is to serve as a research, development, and resource center to improve access to computers by people with disabilities.

4. Adaptive Technology Resource Centre  
J.P. Robarts Library, First Floor  
University of Toronto Information Commons  
130 St. George Street  
Toronto, Ontario, M5S 3H1, Canada  
1-416-978-4360 (phone)  
1-416-971-2629 (fax)  
<http://www.utoronto.ca/atrc/>  
[iris.neher@utoronto.ca](mailto:iris.neher@utoronto.ca)

Adaptive Technology Resource Centre's Web site provides access to a wide variety of sources and information ranging from training and workshops to reviews of assistive technology hardware.

5. Enable's Assistive Technology Program  
(See #7 in Information and Advice About Home Modifications above)

Enable's Assistive Technology department is authorized to provide services for families and individuals with developmental disabilities, traumatic brain injuries, or other physical disabilities. An adaptive technician can evaluate, design, and build adaptations for the home. Enable's adaptive equipment technicians can design and make equipment, help select ready-made equipment, and modify it, if necessary.

## Potential Government Funding Resources

As we all know, funding resources are never equal to funding needs, and monies for assistive technology and home modifications are no exception. Here is a list of some agencies and programs that may provide funding, or funding information, for support services and/or the adaptations and modifications recommended in this manual.

1. U.S. Department of Health and Human Services (DHHS)  
200 Independence Ave., SW  
Washington, DC 20201  
1-202-619-0257 (phone)  
<http://www.hhs.gov/>

The Department of Health and Human Services is the U.S. government's principal agency for protecting the health of all Americans and providing essential human services. Of its many branches, the Administration for Children and Families is the most relevant because it administers the provisions of the Developmental Disabilities Assistance and Bill of Rights Act through the Administration on Developmental Disabilities.

A major goal of the Administration on Developmental Disabilities' programs is to work with state governments, local communities, and the private sector to assist people with developmental disabilities to reach maximum potential through increased independence, productivity, and community integration. They address all elements of the life cycle: prevention; diagnosis; early intervention; therapy; education; training; employment; community living; and leisure opportunities. The programs comprise three state-based efforts. A fourth program addresses issues of concern to residents across the nation.

- a. State Developmental Disabilities Councils (DDCs)

The DDCs in the states promote capacity building and advocacy activities, the development of a consumer- and family-centered comprehensive system, and a coordinated array of services, supports, and other assistance designed to help people with developmental disabilities achieve independence, productivity, integration, and inclusion into the community. The councils address employment issues, and may also address community living activities, child development activities, system coordination, and community education activities.

- b. The Protection and Advocacy (P&A) Program

The Protection and Advocacy (P&A) Program provides for the protection and advocacy of legal and human rights. The P&A systems advocate on behalf of, and provide advocacy services to, persons with developmental disabilities in areas related to their disabilities, including education, abuse and neglect, institutional and rehabilitation

services, guardianship, and housing issues. P&As also pursue class-action advocacy and provide training, information, and referral services.

- c. University Affiliated Programs (UAPs)

University Affiliated Programs provide discretionary grants for public and private non-profit agencies affiliated with a university. Annual grants fund interdisciplinary training, exemplary services, technical assistance, and information/dissemination activities. UAPs support activities that address individual needs from birth to old age and a variety of service issues ranging from prevention to early intervention to supported employment.

- d. Projects of National Significance (PNS)

PNS funds are awarded to public or private non-profit institutions to enhance the independence, productivity, integration, and inclusion into the community of people with developmental disabilities. Monies also support the development of national and state policy.

2. Medicaid

Medicaid is a jointly funded, federal-state health insurance program for certain low-income and needy people. It covers approximately 36 million individuals, including children, the aged, blind, and/or disabled, and people who are eligible to receive federally assisted income maintenance payments. Medicaid home and community waivers take funds that would have been spent on institutional care and allocate them for home modifications for eligible people. Waivers are given for provisions that reduce the need for a more restrictive or costly setting.

# Resource Guide

Medicaid also pays for “durable medical equipment” prescribed by a physician for specific medical conditions of eligible children. To learn more about Medicaid, contact: <http://www.hcfa.gov/medicaid/medicaid.htm> or call the Center for Beneficiary Services Hotline: 1-410-786-7144.

### 3. State Housing Finance Agencies

States may create revolving, low-interest loan funds for home repair and modification. Availability and eligibility requirements vary by state.

State Housing Finance Agencies were created to finance low-income housing by issuing municipal securities and making mortgage loans to eligible borrowers. The agencies’ mandates were expanded to finance other projects that met a variety of state needs, including educational and health care facilities. Each agency also administers several housing loan and grant programs, including three federally authorized programs: the Mortgage Revenue Bond (MRB) program; the Low-Income Housing Tax Credit program (Housing Credit); and the HOME Investment Partnerships Program (HOME).

To find the HFA in your area, contact:

National Council of State Housing Finance Agencies  
444 North Capitol Street, NW,  
Suite 438  
Washington, DC 20001  
1-202-624-7710 (phone)  
1-202-624-5899 (fax)  
<http://www.ncsha.org/>

The Council maintains a directory of State Housing Finance Agencies, which can also be downloaded from its Web site.

### 4. State Departments of Housing and Community Affairs

States may provide grants for home modifications and repairs. Again, availability and eligibility requirements vary by state. Contact your state Department of Housing and Community Affairs (agency names may vary slightly from state to state, i.e., Department of Housing and Community Development, etc.)

### 5. Community Development Block Grants (CDBGs)

CDBGs are block grants of community development funds provided by the Department of Housing and Urban Development (HUD) to address the needs of low-income homeowners in urban areas. Although their main purpose is to reverse urban decay, funds in the form of low-interest loans and grants may be provided to low-income residents in urban areas for home modifications. Funding depends on specific state and local policies. To learn more about Community Development Block Grants, contact:

Community Development Block Grants (CDBG)  
U.S. Department of Housing and Urban Development  
Director, Office of Block Grant Assistance  
Office of Community Planning Development  
451 Seventh Street, SW  
Washington, DC 20410  
1-202-708-3587 (phone)  
<http://www.hud.gov:80/progdesc/cdbg-st.html>

### 6. Community Services Block Grants (CSBGs)

States distribute funds to community action agencies who must use the funds to promote self-sufficiency for all low-income persons. Monies can be used for weatherization and limited home rehabilitation. To learn more about Community Services Block Grants, contact:

The National Community Action Foundation  
810 First Street, Suite 530  
Washington, DC 20002  
1-202-842-2092 (phone)  
1-202-842-2095 (fax)  
<http://www.ncaf.org>  
[info@ncaf.org](mailto:info@ncaf.org)

### 7. Social Services Block Grants (SSBGs)

SSBGs are made directly to states to fund social services tailored to meet the needs of individuals and families in that jurisdiction. Grants are based on the state’s population and each state determines the use of its funds. Eligible projects must bring together the community, the private sector, and local government. Funding must be used for economic self-support to reduce dependency and remedy neglect, abuse, or exploitation of children and adults and to preserve, rehabilitate, or reunite families. Examples of services in various (but not all) states include: child day care; home-based services; child protective services; special services for the disabled; social support services; adoption services; case management; adult protective services; foster care services for children; and

prevention and intervention services. To learn more about Social Services Block Grants, contact:

Administration for Children and Families  
370 L'Enfant Promenade, SW  
Washington, DC 20447  
<http://www.acf.dhhs.gov/toc/index.htm>

#### 8. Low-Income Home Energy Assistance Program (LIHEAP)

The Department of Energy helps low-income individuals with heating and cooling bills and with weatherizing their homes. Priority is given to people with disabilities and older people. To find out more about the program, contact the LIHEAP coordinator for your state or the LIHEAP Clearinghouse (address below). A list of LIHEAP coordinators for each state is available at:

LIHEAP Clearinghouse  
P.O. Box 3838  
Butte, MT 59702  
1-888-294-8662 (phone)  
<http://www.acf.dhhs.gov/programs/liheap/states.htm>

#### 9. Weatherization Assistance Program (WAP)

The U.S. Department of Energy's Weatherization Assistance Program provides grants to states, which in turn contract to local agencies, to promote energy conservation in the households of low-income people, especially the elderly, those with disabilities, and families with children. Under the program, a low-income household is either one whose income is at or below 125% of the federally established poverty guidelines or one that receives certain federal, state, and local cash assistance payments, such as Aid to Families with Dependent Children (AFDC) or Supplemental Security Income (SSI).

For more information, contact your local community services organization, your State WAP office, or:

U.S. Department of Energy  
Weatherization Assistance Programs Branch  
Office of State & Community Programs  
Energy Efficiency and Renewable Energy, EE-44  
1000 Independence Ave., SW  
Washington, DC 20585  
1-202-586-4074 (phone)  
1-202-586-1233 (fax)  
<http://www.eren.doe.gov/consumerinfo/refbriefs/la3.html>

Other links to housing-related sites can be found on the Web at:  
<http://www.mhfa.state.mn.us/pages/Administration/Linkspg.htm#finance>

### Other Possible Funding Sources

1. Christmas in April USA  
1536 16<sup>th</sup> Street, NW  
Washington, DC 20036-1402  
1-202-483-9083 (phone)  
1-202-483-9081 (fax)  
[http://www.christmasinapril.org/general\\_mail@christmasinapril.org](http://www.christmasinapril.org/general_mail@christmasinapril.org)

Christmas in April provides assistance to people who own their own homes, but because of physical or income limitations are unable to cover the costs of home repair. Typically, these individuals have a disability and/or are elderly, but low-income families are also included. Funds come from corporations, foundations, and civic and religious organizations. Individual volunteers also donate money, goods and/or services. Work is done with family members rather than for them.

2. The Make-A-Wish Foundation of America  
100 West Clarendon, Suite 2200  
Phoenix, AZ 85013  
1-602-279-WISH (9474);  
1-800-722-WISH (9474) (phone)  
1-602-279-0855 (fax)  
<http://www.wish.org/home/mawfa@wish.org> (general e-mail)  
[comma@wish.org](mailto:comma@wish.org) (public relations)

The Make-A-Wish Foundation grants wishes to children under the age of 18 with life-threatening (but not necessarily terminal) illnesses. Most wish requests fall into four major categories: "I want to go..."; "I want to be..."; "I want to meet..."; or "I want a...". Referrals are accepted from parents, guardians, and medical professionals such as doctors, nurses, social workers, and child-life specialists. The Foundation's Web site states, "It is our pledge never to deny a wish to an eligible child."

3. A Special Wish Foundation  
2244 South Hamilton Road,  
Suite 202  
Columbus, OH 43232  
1-614-575-WISH (9474) (phone)  
1-614-575-1866 (fax)  
<http://www.spwish.org/main.htm>

Their mission is similar to Make-A-Wish Foundation, but the child must be under the age of 20.



# Resource Guide

## Legal Information

1. Office for Civil Rights (OCR)  
U.S. Education Department  
400 Maryland Ave., SW  
Washington, D.C. 20202  
1-800-421-3481

For school problems related to discrimination based on disability, contact the national Office for Civil Rights. They will refer you to the regional office that covers your geographic area.

2. A free copy of the book, *Legal Rights of the Catastrophically Ill and Injured: A Family Guide*, is available from:

Joseph L. Romano, Esq.  
Commonwealth Bank Building,  
Suite 120  
2 West Lafayette Street  
Norristown, PA 19401  
1-800-331-4134 (phone)  
<http://www.josephromanolaw.com/>  
[info@josephromanolaw.com](mailto:info@josephromanolaw.com)

Joseph L. Romano is an attorney who represents people with disabilities. The book includes chapters on Special Education and School Districts and Dealing with Health Insurers. Updates are posted on the Web site listed above.

3. Disability Legal Support Center  
Commission on Mental and Physical Disability Law  
1-202-662-1570 (voice)  
1-202-662-1012 (TTY)  
1-202-662-1032 (fax)  
<http://www.abanet.org/disability/legalresearch.html>  
[cmpdl@abanet.org](mailto:cmpdl@abanet.org)

This Center provides referrals to lawyers specializing in disability issues. An extensive collection of publications on children with disabilities is available at nominal prices, or go to:  
<http://www.abanet.org/disability/childpub.html>

## Organizations that may be helpful as your child nears adulthood

1. Rehabilitation Services Administration (RSA)  
330 C Street, SW  
Washington, DC 20202  
1-202-205-5482 (phone)  
1-202-205-8352 (TTY)  
1-202-205-9874 (fax)  
<http://www.ed.gov/offices/OSERS/RSA/rsa.html>  
[fredric\\_schroeder@ed.gov](mailto:fredric_schroeder@ed.gov)

RSA provides national leadership for, and administration of, rehabilitation grant programs. These programs provide vocational rehabilitation, supported employment, and independent living for individuals with disabilities to maximize their employability, independence, and integration into the workplace and the community. The programs accomplish this through services, training, research, and economic opportunities. RSA acts as an advocate to ensure the rights of persons with disabilities. It also serves as a resource and clearinghouse of information for service providers at national, regional, state, and local levels. It assists in the development of programs to reduce or eliminate social and environmental barriers experienced by persons with disabilities. The Administration also establishes standards for determining who are individuals with disabilities for purposes of RSA program eligibility and provides leadership in ensuring that all categories of individuals with disabilities receive equitable consideration for access to services. RSA also may help people with disabilities to offset the costs of home modifications.

2. HEATH Resource Center National Clearinghouse on Postsecondary Education for Individuals with Disabilities  
One Dupont Circle, NW, Suite 800  
Washington, DC 20036-1193  
1-202-939-9320 (voice/TTY);  
1-800-544-3284 (voice)  
1-202-833-5696 (fax)  
<http://www.heath-resource-center.org/>  
[heath@ace.nche.edu](mailto:heath@ace.nche.edu)

HEATH provides information on educational support services, policies, procedures, adaptations, transition, and opportunities at American campuses, vocational training schools, adult education programs, independent living centers, and other training entities after high school for people with disabilities. HEATH publishes a newsletter, several directories, and a number of resource papers that focus on specific aspects of education after high school for individuals with disabilities. Topics include accessibility, career development, classroom and laboratory accommodations, financial aid, functional limitations (vision, hearing, mobility, information processing), transition, vocational education, and vocational rehabilitation.

3. President's Committee on Employment of People with Disabilities  
1331 F Street, NW  
Washington, DC 20004  
1-202-376-6200 (voice)  
1-202-376-6205 (TTY)  
1-202-376-6219 (fax)  
[info@pceptd.gov](mailto:info@pceptd.gov)

This organization provides information and technical assistance on employing people with disabilities.

4. National Institute on Life Planning for Persons with Disabilities (NILP)  
Administrative Office:  
Richard W. Fee  
447 East College Ave.  
Jacksonville, IL 62650-2590  
1-217-479-7177 (fax)  
<http://www.sonic.net/nilp/rfee@mac.edu>

NILP is a national organization dedicated to promoting transition and life- and person-centered planning for all persons with disabilities and their families. It helps families obtain the latest information on transition planning, government benefits, advocacy, guardianship, housing, supported employment, etc.

5. Job Accommodation Network (JAN)  
West Virginia University  
P.O. Box 6080  
Morgantown, WV 26506-6080  
Accommodation Information:  
1-800-526-7234 (U.S.);  
1-800-526-2262 (Canada)  
ADA Information:  
1-800-ADA-WORK (232-9675) (U.S.)  
1-304-293-5407 (fax)  
<http://www.jan.wvu.edu/english/homeus.htm>

The Job Accommodation Network (JAN) is an international toll-free consulting service that provides information about job accommodations and the employability of people with functional limitations. Anyone may call JAN for information. Calls are answered by consultants who understand the functional limitations associated with disabilities and who have instant access to the most comprehensive and up-to-date information about accommodation methods, devices, and strategies. JAN preserves the confidentiality of communication between caller and consultant. The mission of JAN is to assist in the hiring, retraining, retention, or

advancement of persons with disabilities by providing accommodation information.

6. Centers for Independent Living (CILs)  
Centers for Independent Living are private, non-profit corporations that provide services to maximize the independence of individuals with disabilities and the accessibility of their communities. Centers are located throughout the country and provide core services such as advocacy, independent-living skills training, information and referral, and peer counseling. For information on the CILs and their locations, contact:

Independent Living Research Utilization (ILRU)  
2323 South Shepherd, Suite 1000  
Houston, TX 77019  
1-713-520-0232 (voice)  
1-713-520-5136 (TDD)  
1-713-520-5785 (fax)  
<http://www.ilru.org>

## Transportation and Travel

1. Project ACTION (Accessible Community Transportation In Our Nation)  
700 13<sup>th</sup> Street, NW, Suite 200  
Washington, DC 20005  
1-800-659-6428 (voice/TTY)  
1-202-347-4157 (fax)  
<http://www.projectaction.org>  
[project\\_action@nessdc.org](mailto:project_action@nessdc.org)

Project ACTION (Accessible Community Transportation In Our Nation) is a national program that supports innovation and cooperation in solving transit accessibility problems. Project ACTION works with both the disability community and the transit industry to provide assistance in implementing the transportation provisions of the Americans with Disabilities Act (ADA). Project ACTION provides various direct forms of technical assistance and training, and main-

tains a library of information and materials addressing accessible transportation for people with disabilities. The Project disseminates at no charge a newsletter, training curricula, surveys, technical materials, and reports.

2. Access for Disabled Americans  
436 14<sup>th</sup> Street  
Oakland, CA 94610  
1-510-419-0523 (phone)  
1-510-419-0768 (fax)  
<http://www.maxpages.com/disabledaccess>

Access for Disabled Americans publishes a list of organizations that provide services, including outdoor adventure, for people with disabilities.

3. Miracle Flights for Kids  
2756 North Green Valley Parkway,  
Suite 115  
Green Valley, NV 89014-2100  
1-702-261-0494;  
1-800-359-1711 (phone)  
1-702-261-0497 (fax)  
<http://www.miracleflights.com/amcgee@miracleflights.com>

4. The National Park Service  
Office of Public Inquiries  
1849 C Street NW, Room 1013  
Washington, D.C. 20240  
1-202-208-6843 (phone)  
<http://www.nps.gov>

Ask for a copy of *The National Park System Map and Guide*. In addition, each national park has a page on the Internet that describes its accessibility. You can then call the park for specifics.

# Resource Guide

## Product Catalogs/ Equipment

1. Ableware  
Maddak, Inc.  
6 Industrial Road  
Pequannock, NJ 07440-1993  
1-973-628-7600 (phone)  
<http://www.maddak.com/>  
  
Offers home health care and  
rehabilitation products.
2. Care Medical  
1877 NE 7<sup>th</sup> Avenue  
Portland, OR 97212  
1-800-443-7091 (phone)  
<http://www.caremedical.com>  
  
Features home health equipment  
and supplies.
3. Jesana Ltd.  
P.O. Box 17  
Irvington, NY 10533  
1-800-443-4728 (phone)  
1-914-376-0021 (fax)  
  
Specializes in augmentative commu-  
nication, mobility, furniture, posi-  
tioning products, etc.
4. Sammons-Preston  
P.O. Box 5071  
Bolingbrook, IL 60440-5071  
1-800-323-5547 (phone)  
1-800-547-4333 (fax)  
  
Distributor for Tumble Forms  
(shapes, modules and equipment  
for positioning and seating).

## Magazines

1. *Exceptional Parent Magazine*  
555 Kinderkamack Road  
Oradell, NJ 07649-1517  
1-201-634-6550 (phone)  
1-201- 634-6599 (fax)  
<http://www.exceptionalparent.com/>
2. *Sports 'N Spokes*  
2111 East Highland Ave., Suite 180  
Phoenix, AZ 85016-4702  
1-602-224-0500;  
1-888-888-2201 (phone)  
1-602-224-0507 (fax)  
[http://www.coastresources.com/  
sns/index.htm](http://www.coastresources.com/sns/index.htm)  
[snsmagaz@aol.com](mailto:snsmagaz@aol.com)
3. *Special Child Online Magazine*  
[http://www.specialchild.com/  
index.html](http://www.specialchild.com/index.html)

# Index

## A

Abilities Expos, 81, 87  
access - controlling, 36  
accessibility, general, (*see* Chapters 3-5), 1, 2, 5, 10, 12, 13, 15, 16, 33, 71, 81, 85-86, 93  
bathroom, 10, 36-37, 39, 71-72, 83, 92, 93  
decks, decking, 22, 65, 66, 71, 73, 94  
doorways, 33-35, 39, 92, 93  
driveway, 17-21  
entrance, exit (to home), 17, 23, 25, 27, 92  
exterior, 16-17, 21-29, 65-66  
kitchen, 10, 60-64, 71, 93  
laundry, 64-65  
patios, 65, 94  
paths, *see* sidewalks, walkways  
school, 9-11, 77, 88-89, 94-95  
transportation, 11, 17-23  
ADA (Americans With Disabilities Act), 89  
ADLs (activities of daily living), 1, 88  
advocacy, 89  
aides, 82, 94  
air conditioning, 73  
American National Standards Institute (ANSI), 24  
Americans with Disabilities Act (ADA), 89  
amusement parks, 80  
anti-scald devices, 48  
apartments, 85, 92  
appliances (kitchen), 63-64  
assistive technology, 80, 87, 88, 94, 102-103  
au pairs, 86  
autonomy (*also see* independence), 2, 77, 80-81, 84, 92, 95

## B

basement, 94  
bathrooms, general, 10, 39-44, 71, 79, 83, 92, 93  
access, accessibility, 10, 39, 83, 92, 93  
bath/shower seats, 89, 40, 45-46, 52, 92  
—inflatable cushion type, 49  
bath/shower lifts, 40, 45, 47, 52, 71, 88  
bathing, 39, 45-46, 83, 84  
bathtub, 40, 45, 49, 71, 84, 93  
—oversized, 49, 71  
—raised, 49, 71  
—side-opening, 49, 71  
—spa/whirlpool tubs, 49, 71, 93  
—transferring to and from, 40  
—whirlpool/spa tubs, 49, 52, 71, 93  
—wide ledge, 49  
bidets, 57, 71  
changing tables, 44, 58, 71, 83  
commodes, 57, 93

controlling access, 39  
grab bars, 44, 52, 92  
hand-held shower nozzles/hoses, 48, 71  
layout, 39-41, 71  
lighting, 55  
potty chairs, 56-57  
proximity to bedroom, 39, 71, 72  
shower stalls, 50-51, 71, 93  
—transferring to and from, 40, 50-51  
sink, 53-55, 93  
—adjustable height, 54, 71  
—faucets, 55, 71  
—mirrors, 55  
—pipe installation, 54  
—scald control, 71  
—soap dispenser, 71  
—wheelchair access, 44, 53, 54, 71  
size, 39-41, 54  
spa tubs, 37, 52  
toilets, 56-57, 71  
—heat and water cleansing apparatus for, 57  
—toilet chairs, 56-57, 71  
—transferring to/from, 41-43, 56-57  
beds, 9, 10, 13, 80  
bedroom, child's, 6, 10, 71, 72, 84, 94  
bedroom/bath suite, 84, 85  
behavioral issues/problems/improvements, 9, 11, 81, 87  
bicycles, bicycling, 9, 86, 88  
boardwalk, 22  
building permits, 28

## C

catheterization, 81, 87  
changing needs, *see* developmental stages and Chapter 2  
changing tables, 44, 58, 71, 83  
child-proofing, 36  
civic organizations, 77  
climate, 86  
climate control, 73  
college, 93  
communication problems, therapy, 8, 81, 86  
community, (*also see* neighborhood), 74-75  
computers, 10, 80, 82, 88, 92, 93, 94  
concrete walkways, 22  
contractors, 28  
countertops, 54, 61, 63  
crying, 8, 87

## D

daycare, day programs, 8  
decks, decking, 22, 65, 66, 73, 94  
developmental checklist, 97-98  
developmental stages, (*also see* Chapter 2), 1-3, 81  
adolescence, 11-13, 21, 60, 92  
infant to toddler, 7-8, 88  
preschool to school age, 9-11, 81, 88, 91, 92  
teenage years, 88, 93  
toddler to preschool, 8-9, 81, 88, 92  
disability organizations, 87, 99-102, 105-107  
doors and doorways, 10, 28-32, 33-35, 37, 71, 79, 92, 93, 94  
accordion, 71  
automatic door closers, 32  
bathroom, 39-41, 81  
bi-fold doors, 34, 71, 93  
door knob turners and extensions, 29  
dual-swing hinges, 34  
double doors, 30  
French doors, 12, 30, 84  
front door, 23, 27-28  
hardware, 28, 34-35, 71, 92  
mini-ramps at door, 31  
moving a door, 30  
pocket doors, 34, 71, 93  
power door openers, 29, 35, 71  
sills, 31, 34, 71  
swing-clear hinges, 34  
thresholds, 31, 34  
turning radius needed, 32, 33, 35, 40  
widening, 33, 39  
driveways, 17-21

## E

early intervention, 7, 8, 83, 86, 96  
education; educational/school system, 8, 9, 10, 11, 77-78, 80-82, 87-89, 94  
electrical switches and outlets, 73, 80, 92  
electrical system, 73, 80  
electronics equipment, 73, 88  
elevators, 38, 88, 92, 93  
emotional issues/difficulties/support, 9, 11, 79, 84, 93  
entitlements (*also see* legal rights), 87, 88-89  
entrances, 22, 27-32, 73, 86, 92  
on grade, 27, 73  
environmental control units, 73  
equipment, 8, 9, 80, 86, 87, 88, 92-93, 95  
Exceptional Parent Magazine, 87, 108

# Index

## F

falls, 9  
families participating in study, 3-4  
family life, 9  
family room, 84  
faucets, 55, 62  
feeding disorders, 8  
financial aid, 86, 103-105  
fire exits, 73  
flooring and floor coverings, 68, 71, 92  
    kitchen floors, 64  
furniture, furniture arrangements, 79, 92  
future planning, 2, 8, 15, 84  
funding, 103-105

## G

G tubes, 88  
gait trainers, 88  
game room, 93  
garages, 22, 71, 73, 92  
grab rails or bars, 44, 52, 56, 92  
great room, 71  
grooming, 39  
grounds, 73

## H

hallways, 10, 33, 35, 71, 92, 93  
heating, 73  
    home environment/modifications, (*see*  
        Chapters 3, 4, *and* 5), 5-6, 8-10,  
        12-13, 79, 88, 92, 93, 100-102  
    bedroom, child's, 6, 71, 72, 84, 94  
    cost, 16  
    family rooms, 6  
    ideal, (*see* Chapter 5), 70-73, 93-94  
    one-level, 6, 70, 79  
hospital, 77, 86  
hospital beds, 10, 13  
hot tub, 73, 82, 93, 94  
house size, 9, 10, 11, 93  
house type, 6  
    older, 85  
    one-level ranch, 6, 75, 77, 86, 92  
    raised ranch, 85  
    split-level, 85, 92  
    two story, 92  
HVAC (heating, ventilation, air  
    conditioning), 73

## I

inclusion, 11, 81, 83, 88-89  
Individual Educational Plans (IEPs), IEP  
    Meetings, 88  
intercoms, 10  
independence, 1-2, 6, 11-12, 60-62, 75, 77,  
    79-81, 86, 88, 92-95  
interview content, 7, 85  
interview process, 3-4

## J

jogging stroller, 88

## K

key turners, 28  
keyless locks, 28  
kitchen, 10, 60-64, 71, 93  
    accessibility, 10, 71, 93  
    baby-proofing, 60  
    carpeting, 60, 92  
    cooking, 81  
    cooking appliance, equipment, 62-64,  
        88  
    countertops, 54, 61, 63, 71, 93  
    faucets, 62  
    floors, 65  
    independence in, 60-61  
    modifications, 10  
    refrigerators, 62, 71  
    shelving and storage in, 61-62, 71-72  
    sinks, 62, 71  
    size, 62-71  
    tables, 72

## L

landings (for ramps), 25-26  
laundry, 65, 73  
layout, (*also see* accessibility *and* specific  
    rooms), 12, 36, 41, 71  
legal rights, 81, 87, 88-89, 106  
lifts, 3, 38, 88  
    bath, 88, 92  
    ceiling mounted, 57, 72  
    elevators, 38, 88, 92, 93  
    outdoor, 28  
    platform, 38  
    portable, 40, 77  
    stair lift with seat (chair type), 38  
    swimming pool, 65, 67, 73, 82, 88, 92  
    van 17-20, 88  
lighting, 72, 94  
living room, 84  
location, home - *see* neighborhood  
locks, 28

## M

Make-A-Wish Foundation, 87, 105  
medical insurance, 9  
medical condition/problems/issues, 8, 9, 11  
medical records, 86  
medical treatment, 86  
medications, 86  
methodology, 2-4, 91  
mirrors, 55  
mobility devices, 8, 16  
    scooters, 93  
    specialized bicycles/tricycles, 8  
    strollers, 8  
    wheelchairs, 8, 9, 92, 93  
mobility needs, 9  
monitoring, monitors, (*also see* intercoms)  
    8, 73  
moving, 2, 8, 11, 69, 74, 82, 85, 86  
mud room, 72, 73

## N

nannies, 86  
National Parks, 87, 107  
neighborhood, neighbors, 2, 8, 74-78, 82,  
    86, 93, 94  
networking, 80  
NJ Assistive Resource Program (TARP), 28  
nursery school, 8, 81, 83, 88

## O

occupational therapy, 80, 81, 86  
outdoors, 65-66, 94  
    walkways and paths, 22, 66, 73, 92, 94  
ovens, 63-64

## P

patios, 65-66, 73, 94  
peer relationships, 93-95  
pets, 80, 82, 94  
physical therapy, 80, 81, 86  
playing, play equipment, playgrounds, 9,  
    73, 74, 80, 81, 88, 92-93  
playroom, 72  
pools, *see* swimming pools  
porches, 66, 73, 94  
positioning, 8  
posture, 86  
preschool, 8, 81, 83, 88  
privacy, 5, 10, 11, 13, 69, 72, 73, 79, 80,  
    83-84  
psychotherapy, 86

## R

ramps, 9-10, 23-25, 38, 73, 92, 93  
    disguised, 23  
    in swimming pool], 67  
    portable, 10, 23  
recreation, 5, 80, 92  
reflux, 8  
remote control door openers, 28, 93  
research methodology, 2-4, 91  
respite care, 8, 11, 82, 83, 86  
respiratory problems, 73  
restrooms, public, 83

## S

safety, 2, 5, 69  
school, 69, 77-78, 81, 82, 88, 89, 91,  
    94, 95, 96  
    accessibility issues, 9, 11, 88, 94, 95  
    aides, 94  
    mainstreaming/inclusion, 11, 81, 83,  
        88-89, 94  
    school buses, 21-22  
    special schools, 82, 83, 89, 94  
    starting, 9  
    transportation, 9, 77, 83  
seating, *see* positioning  
seizures, 8, 9, 86  
self-esteem, 2, 80  
sexuality issues, 11  
shunts, 87, 88  
siblings, 9, 82, 84, 86, 87  
sidewalks, 22, 94  
skylights, 72  
sleep apnea, 8  
spasms, 24, 32  
Special Olympics, 75, 83  
speech therapy, 8, 80, 81, 86  
social life; socialization; socializing, social  
    supports, 2, 6, 9, 11-12, 74-75, 77,  
    79-84, 87, 88, 91-95  
sports, 75, 80, 81, 82, 83, 87, 93, 94  
stages of development, *see* developmental  
stages  
stairs, 92  
    exterior, 26  
    interior, 3, 38  
    lifts, 38, 88  
    stair climbers, 88  
standers, 8, 9  
State disability agencies, 86, 102, 103  
storage space, 6, 73  
strollers, 8, 89  
study sample, 2-6, 91  
support agencies, 86, 88

support groups, 88  
surgeries, 9, 92  
swimming pools, 6, 10, 65, 67, 73, 92, 94

## T

technology, 80, 88, 89, 94  
telephone, 80, 87  
therapy (*also see various types*), 86  
therapy room, 72  
thermostat, 73  
toddler stage, 60, 92  
toileting, 9, 11, 39, 59, 81, 83  
town, *see* neighborhood *and* community  
    trade shows, 81, 87  
transferring, 9, 13, 40-41, 72, 80, 86  
    trapeze, 80  
transportation (*also see vans*), 11, 17-23,  
    107  
    school, 86-87  
treatment, 86-87

## V

vacations, 80, 82, 87, 107  
vans, 9, 10, 17-20, 88  
    conversion vans, 18-20, 73  
    lifts for vans, 10, 17-20, 73, 88  
variances (zoning), 16  
ventilation, 73

## W

walkers, 92  
walkways, 21-23  
water fountains, 94  
wheelchairs, 9, 10, 11, 13, 74-75, 85, 92  
    damage control, 37, 71  
    power, 24  
    transfers, 9, 40-43, 72, 86  
    turning radius, 32, 33, 35, 40, 41  
whirlpools, 41, 67, 73, 93  
windows, 72, 79  
workstations, 10, 13, 80

## Y

yard, 65, 94

## Z

zoning approval, 16

## *Notes*

